

Prediction and Measurement of Stadia Dynamic Properties

Paul Reynolds¹, Aleksandar Pavic¹ and Michael Willford²

¹The University of Sheffield
Department of Civil and Structural Engineering
Sir Frederick Mappin Building
Sheffield, S1 3JD, UK.

²Arup
13 Fitzroy Street
London
W1T 4BQ, UK.

ABSTRACT

This paper describes an investigation of the dynamic behaviour of the City of Manchester Stadium in Manchester in the UK. A programme of pre-test numerical modelling, ambient and shaker modal testing and post-test FE modelling is described, with a view to providing insight into how future models of similar structures may be constructed in the future to better represent the actual dynamic behaviour. The modal testing of the structure showed a number of global and seating deck modes that are possible to be excited by dynamic crowd excitation. Some understanding of these modes was possible using simplified pre-test models, but to more accurately represent the behaviour of the stand, it was necessary to develop a full 3D FE model of the whole stand. This provides accurate determination of global mode shapes and a family of modes on the cantilevered tiers. Further work is required to improve the post-test FE model, including characterisation of the behaviour of the non-structural elements, more accurate determination of cracked reinforced concrete section properties and inclusion of the roof structure.

INTRODUCTION

Vibrations in sports stadia under crowd excitation are becoming increasingly problematic. The main reasons for this are threefold:

1. stadia structures are becoming more slender due to increasing efficiency of construction technologies,
2. crowds are becoming more lively than was previously the case, particularly when incidental music is played during sports events, and
3. sports stadia are being increasingly used as pop/rock concert venues, during which they experience increased dynamic loading due to synchronised crowd activity (dancing, jumping, etc.).

As a result, it is becoming increasingly important for designers to be able to predict the susceptibility of stadia to excessive vibration at the design stage. In order to do this it is necessary to predict the modal properties of stand structures and their likely vibration responses under crowd dynamic excitation. However, experience has shown [1] that even sophisticated numerical models produced by experienced designers may be significantly in error. There is, therefore, a motivation to carry out back-analysis of the dynamic properties and response of existing stadia to compare with field measurements with a view to providing improved guidance on numerical modelling at the design stage in the future.

This paper presents the results from one such case where pre-test modelling, dynamic testing and post-test modelling have been carried out to better understand how to model similar structures in the future.

THE STRUCTURE

The structure considered here is the City of Manchester Stadium in Manchester, UK. This stadium was built for the Commonwealth Games in 2002 and is now home to Manchester City Football Club. An external and internal view of the stadium is shown in Figure 1.



Figure 1: External and Internal Views of the Stadium.

The stadium has a modern bowl configuration providing all seats in the stadium with a good view of the football pitch. The structure itself has an in-situ cast reinforced concrete (RC) frame and the seating decks themselves are constructed from precast concrete (PCC) L-shaped seating deck units simply-supported between the RC frames. A typical cross-section through the West Stand is shown in Figure 2. It should be noted that there are a number of movement joints in the corner areas of the stadium, so the apparent continuous bowl can actually be considered structurally to be several discrete stands.

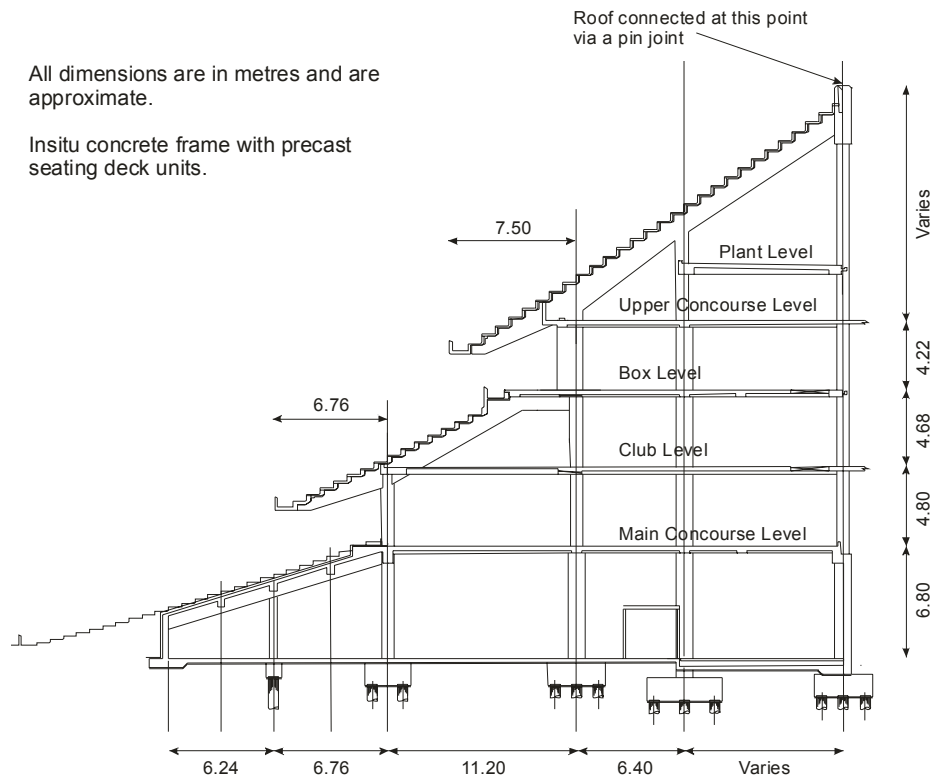

Figure 2: Typical Section Through the West Stand.

It can be seen from Figure 2 that in addition to the seating decks and concourse areas, the stadium also provides accommodation for executive boxes, hospitality suites and office, etc. As a result, there are many walls and other non-structural elements that have a potential for changing the dynamic properties of the structure compared with the bare structure.

The stadium roof is connected to the stand at the top of the columns at the back of the stand and is also supported by a system of cables suspended from pylons outside of the stadium.

PRE-TEST MODELLING

During the structural design, the pre-test modelling was carried out on the South Stand structure (which is similar but has only a lower cantilevered tier) using two different numerical models. The first model was a detailed 3D model of a single frame that was used to analyse the vertical modes of the seating deck. The second model was a 3D model of an entire stand, which was designed to investigate the global fore-and-aft and side-to-side sway of the entire stand.

Determination of Modal Properties of the Seating Deck

The first model was a 3D FE model created using the MSC.Nastran FE code. This was a detailed model of a single tier of the seating deck, in which a single in-situ cast concrete frame, internal floor areas and discrete PCC seating deck units were modelled using 3D brick elements. Additionally the internal columns were modelled using beam elements. The dynamic Young's modulus of the concrete was taken to be 38 kN/mm², but the cracked stiffness of the raking beam was assessed using the Oasys ADSEC program taking account of the reinforcement in the section and the anticipated 'in-service' bending moments. This model was intended to be used to determine vertical natural frequencies of the cantilevered seating deck, which is the most vulnerable area of the grandstand to vertical crowd-induced dynamic loading.

Modelling of the interaction between the precast seating units and the main cantilever beams was an area of uncertainty. The units are not fully monolithic with the beams or with each other, but are seated on a grout bed on the main beams and the previous (lower) precast unit, and secured using a small number of steel dowels. A sensitivity analysis was performed to assess the effect of different degrees of fixing between raking beams and precast units on the natural frequency. It was found that the natural frequency of the 1st mode of vibration (Figure 3) varied between 5.03 Hz and 5.84 Hz depending on the assumed degree of fixity.

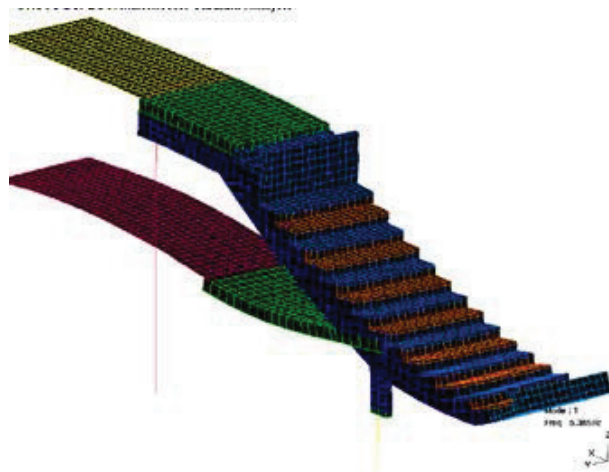

Figure 3: 1st Vertical Mode of Vibration of Cantilevered Tier.

Determination of Global Modal Properties of the Whole Stand

A second numerical model was constructed to determine the global modal properties of the South Stand. The model was created using the Oasys GSA analysis software, which is a general structural analysis program used in the civil engineering sector. The amount of detail in the model was reduced compared with the single tier model, to limit both the user and computer processing time. However, the entire South Stand was modelled as this was necessary for a realistic determination of the global modal properties.

The model, which is shown in Figure 4, included foundations, transverse frames (columns, raking beams and floor beams), floor slabs, precast seating units and a concrete blockwork wall along the outer perimeter. Only the

precast units that are fixed to the frames were modelled explicitly, and their density was modified so as to account for the mass of the other precast units that have expansion joints.

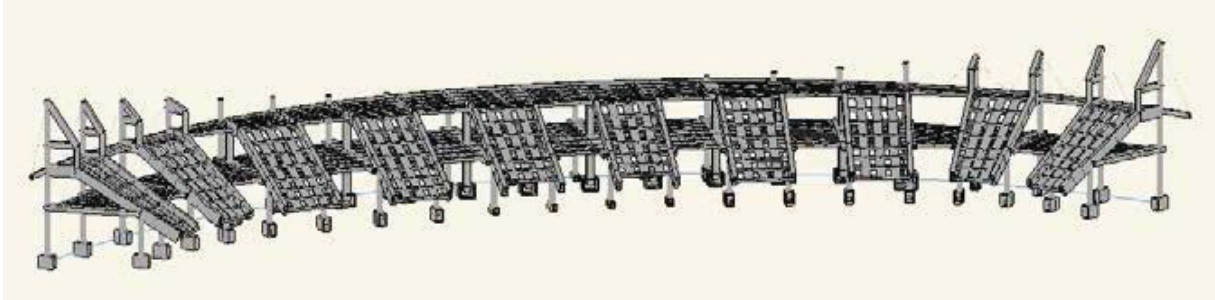

Figure 4: GSA Model of the Entire South Stand.

The first side-to-side sway mode of vibration predicted by this model is shown in Figure 5. The model was analysed in two configurations. The first configuration was simply the empty frame, whereas the second configuration included the 'non-structural' blockwork wall that was located around the perimeter of the stand. The natural frequencies predicted for these two configurations were 1.0 Hz and 7.0 Hz. This demonstrates the difference in predicted frequency arising from including or not including non-structural elements that have the potential to provide a significant amount of stiffness.

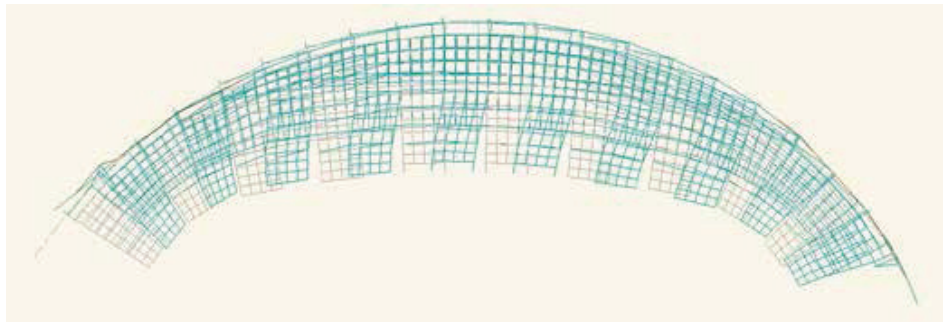

Figure 5: Global Side-To-Side Sway Mode of South Stand.

DYNAMIC TESTING

Three types of dynamic testing and monitoring were carried out at the stadium:

1. multi-shaker modal testing to determine vertical modes of the seating decks on the West Stand,
2. ambient modal testing to determine global modes of the West Stand, and
3. dynamic monitoring during a rock concert event.

This paper is concerned with the prediction and measurement of the dynamic properties of the empty stand, so it is the first two types of testing that are of interest here. The measurements were carried out over a three-day period in October 2004.

Shaker Modal Testing of Seating Decks

Multi-shaker modal testing was performed on the seating decks to determine the vertical modes likely to be excited by vertical crowd dynamic excitation. It was anticipated, as demonstrated by the pre-test modelling, that the lowest modes of interest, i.e. those that would be most readily excited by the occupants, would engage primarily the cantilevers in vibration.

Considering the typical cross-section of the West Stand shown in Figure 2, it was decided to carry out the modal testing on the middle and upper tiers, both of which contained cantilevers of significant length. The test grids for the middle and upper tiers are shown in Figure 6. In both cases, a grid was defined that included test points at the

tip of the cantilevers along the whole of the length of the stand. Additional rows of test points were also included at the middle of the spans behind the cantilevers.

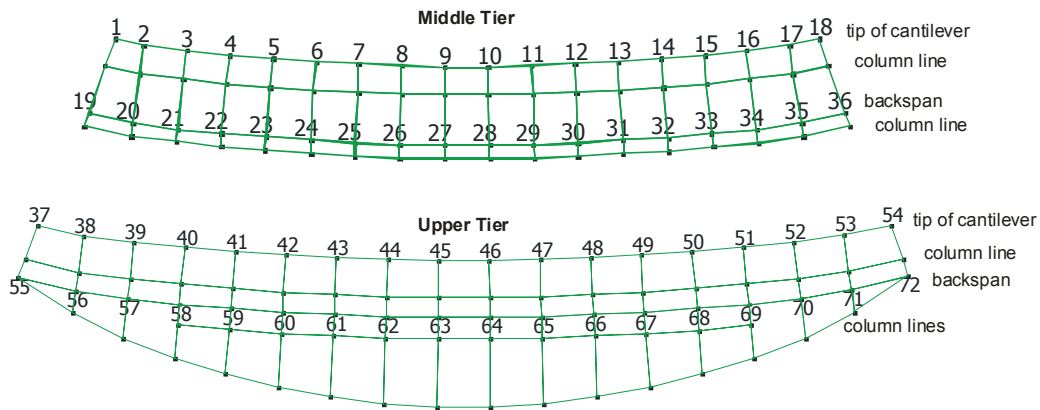

Figure 6: Middle and Upper Tier Test Grids for Shaker Testing.

The multi-shaker testing procedure was the same for both tiers. Excitation was provided by two APS Dynamics Model 400 electrodynamic shakers. These were operated in reaction mode, meaning that the force was generated by accelerating reaction masses attached to the shaker armatures. The force magnitude was measured by attaching accelerometers to the reaction masses to measure their acceleration and by multiplying the measured accelerations by the reaction mass. A view of one of the shakers, positioned at the tip of one of the cantilevers, is shown in Figure 7.



Figure 7: View of Shaker and Accelerometer.

The accelerometers used to measure the structural responses and the acceleration of the shaker reaction masses were Endeveco Model 7754-1000 piezoelectric accelerometers. These high-quality accelerometers had a sensitivity of 1000 mV/g, a noise floor of less than 10 µg and a low-frequency limit of less than 0.5 Hz. To measure the structural responses they were attached to baseplates which could be levelled to ensure their accurate alignment as shown in Figure 7. Two accelerometers were used to measure the shaker forces and another 16 were used to measure structural responses.

Data acquisition was carried out using a Data Physics Mobilyzer II spectrum analyser, which has a total of 24 input channels and 4 output channels. This spectrum analyser, controlled using a notebook PC connected via a

100 Mbps Ethernet connection, provided facilities for examination of the acquired data and immediate calculation of Frequency Response Functions (FRFs).

Uncorrelated continuous random excitation was used to carry out the modal testing. A total of 80 frames of data of length 20 s were acquired with a 75% overlap, to which a Hanning window was applied. A frequency range of 20 Hz baseband was selected on the spectrum analyser, corresponding with a sampling rate of 51.2 Hz

The testing proceeded by positioning both shakers at the tip cantilever on the middle tier, at test points 9 and 12. The response accelerometers were positioned at 16 of the test point locations and FRF measurements were made. The 16 response accelerometers were then moved to the next 16 locations and again the FRF measurements were made. This continued until all required FRFs had been acquired. This process was repeated for the upper tier, with the shakers positioned at test points 45 and 48. In addition, whilst carrying out the testing on the middle tier, some response measurements were made on the upper tier cantilever to determine if there was any coupling between the two tiers.

Modal parameter estimation was carried out using polyreference algorithms implemented in the ME'scope software [2]. The modal properties estimated from the middle and upper tiers are shown in Tables 1 and 2 respectively.

Table 1: Middle Tier Modal Properties.

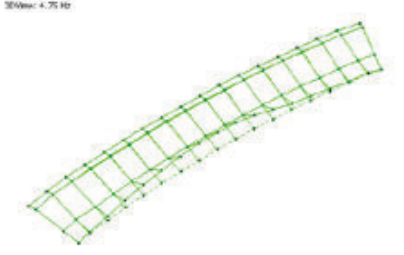
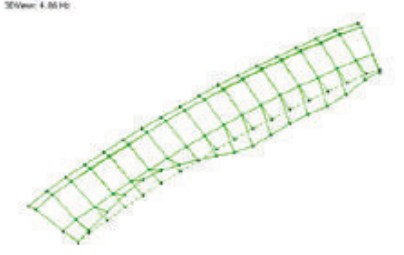
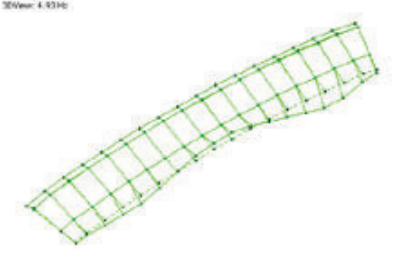
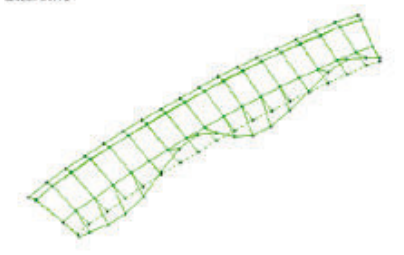
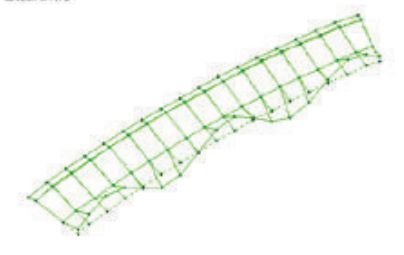
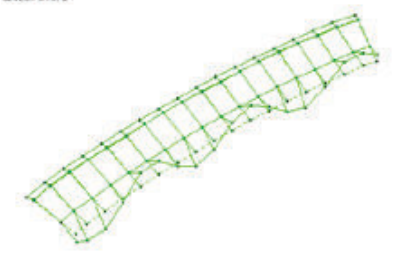
 <p>f = 4.75 Hz, ζ = 1.6 %</p>	 <p>f = 4.87 Hz, ζ = 1.4 %</p>	 <p>f = 4.94 Hz, ζ = 1.1 %</p>
 <p>f = 5.17 Hz, ζ = 1.3 %</p>	 <p>f = 5.44 Hz, ζ = 1.6 %</p>	 <p>f = 5.75 Hz, ζ = 0.9 %</p>

On both tiers, it is quite apparent from a visual examination of the mode shapes that the lowest modes of vibration engage primarily the cantilevers. The modal displacements at test points corresponding with the mid-span points of the back spans did not move significantly compared with the cantilevers themselves.

Ambient Modal Testing to Determine Global Modes of Vibration

Ambient modal testing (also known as operational or output-only modal testing) is often carried when it is difficult or infeasible to provide sufficient artificial excitation to a structure to enable the use of input-output testing techniques. In the case of a large stadium such as the one considered here, ambient modal testing is a useful technique to determine the modal properties of the “global” modes of vibration, i.e. those which engage an entire stand in vibration as opposed to just a single tier or cantilever. It is important to characterise these modes as it has been shown that it is possible that components of force from human activities might be able to excite these modes [3].

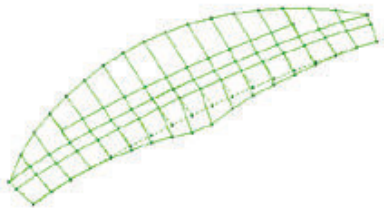
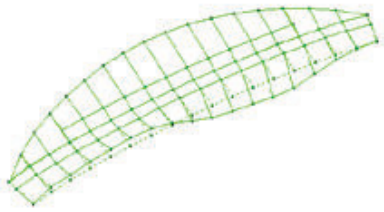
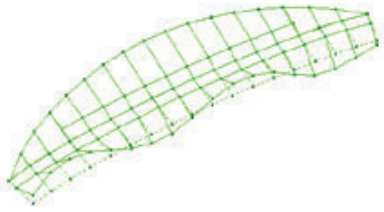
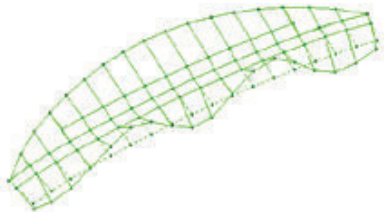
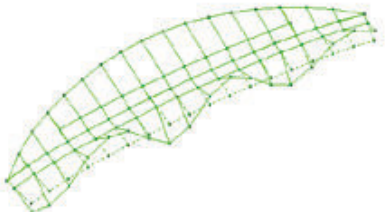
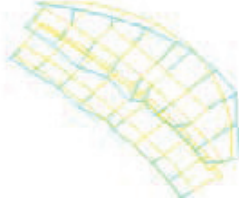

Table 2: Upper Tier Modal Properties.

 <p>3DView: 4.90 Hz</p> <p>$f = 4.90 \text{ Hz}, \zeta = 2.0 \%$</p>	 <p>3DView: 5.17 Hz</p> <p>$f = 5.17 \text{ Hz}, \zeta = 0.6 \%$</p>	<p>not estimated</p>
 <p>3DView: 5.27 Hz</p> <p>$f = 5.27 \text{ Hz}, \zeta = 1.8 \%$</p>	 <p>3DView: 5.58 Hz</p> <p>$f = 5.58 \text{ Hz}, \zeta = 1.9 \%$</p>	 <p>3DView: 5.87 Hz</p> <p>$f = 5.87 \text{ Hz}, \zeta = 2.0 \%$</p>

Global modes of vibration are typically fore-and-aft and side-to-side sway modes where the maximum response is towards the top/back of the stand. Therefore, a row of triaxial measurements were made at the top of the stand. Global modes, particularly fore-and-aft modes, also tend to produce a measurable response elsewhere on the structure. Therefore additional rows of triaxial measurements were made on the two cantilevers.

The ambient responses were measured using the same accelerometers and data acquisition hardware as were used for the shaker modal testing. Following data acquisition, the vibration responses were analysed using the enhanced frequency domain decomposition (EFDD) algorithm as implemented in the ARTeMIS ambient modal parameter estimation software [4]. The first three measured global modes of vibration of the stand are shown in Table 3.

Table 3: Modal Properties of Global Modes of Vibration.

 <p>$f = 2.36 \text{ Hz}$ (1st fore-and-aft)</p>	 <p>$f = 2.38 \text{ Hz}$ (2nd fore-and-aft)</p>	 <p>$f = 3.22 \text{ Hz}$ (1st sway)</p>
---	---	---

During the ambient modal parameter estimation process, it was noted that there were a number of apparent lower 'modes of vibration' that could be estimated using the EFDD algorithm. However, these were considered to be too low to be meaningful structural global modes of the stand. They also had the characteristic that they appeared in several of the singular value decomposition (SVD) plots used for the parameter estimation, as can be seen in Figure 8. This is a characteristic that is typical of forced non-resonant structural vibration [4].

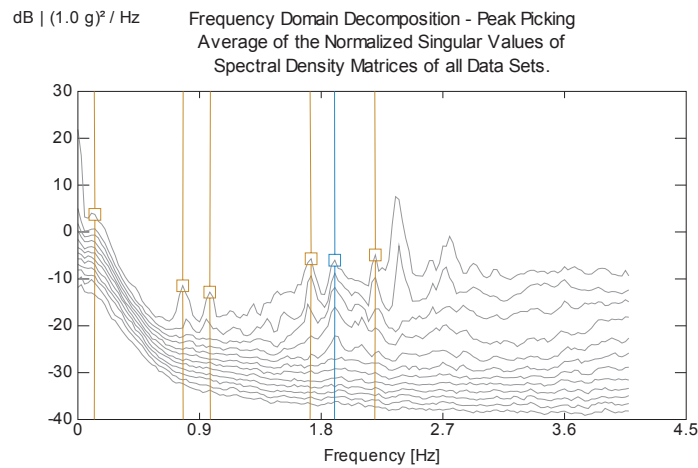

Figure 8: Averaged SVD Plot Showing Peaks Corresponding to Probable Roof Modes.

The most likely explanation for this behaviour is that the stadium roof, which was attached to the stand at the top of the columns at the back of the stand, and which was not included in the ambient testing test grid, was being excited by the ambient conditions at the same time as the stand itself. The vibrations of the roof were then causing energy to be transmitted to the rest of the stand at frequencies corresponding to the roof natural frequencies. This was being perceived by the measurements on the stand as a forced excitation at specific frequencies. As it is the actual global modes of the stand that are of main interest for vibration serviceability, the modes that were thought to be roof modes were discarded from the analysis.

POST-TEST FE MODELLING

Model Construction

Following the dynamic testing, a detailed 3D FE model of the entire West Stand was created using the ANSYS FE code. A full 3D model is required to simulate the full range of dynamic properties of interest on the stand, i.e. both the local cantilever modes and the global fore-and-aft and side-to-side sway modes. A view of the FE model created is shown in Figure 9.

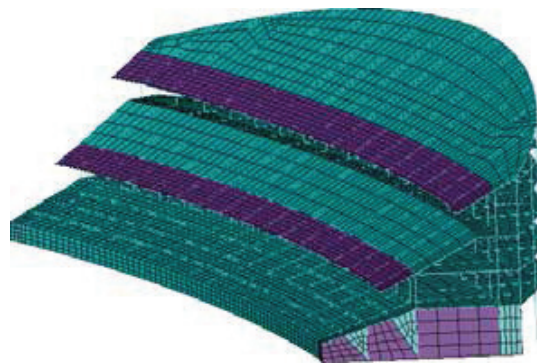

Figure 9: 3D FE Model of West Stand.

The entire concrete structure was assumed to be monolithic with a Young's modulus of 38 kN/mm^2 , including the precast seating deck units which were actually attached to the insitu cast concrete frame using dowel connectors. However, at the small strains likely during low-level vibration, it was deemed that this connection could be assumed to be monolithic considering the sensitivity study done during the pre-test modelling. The concrete frames were modelled using beam elements, using offsets as appropriate to represent the difference between the centroids of the slabs/precast units and the beams themselves. In cases where the beam cross-sections varied along their lengths, the beam elements were specified to be tapered. The seating deck units and internal floor

areas were modelled using orthotropic shell elements with stiffnesses calculated to represent the actual cross-sections, which were not uniformly flat.

Post-Test Modelling Results

At time of writing, the FE model as described above had been analysed to determine global and local modal properties. A summary of the first 3 global modes and the first few cantilever modes are given in Table 4.

Table 4: Modes from 3D FE Model.

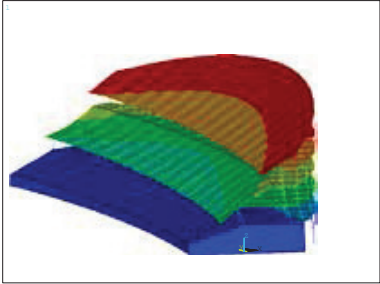
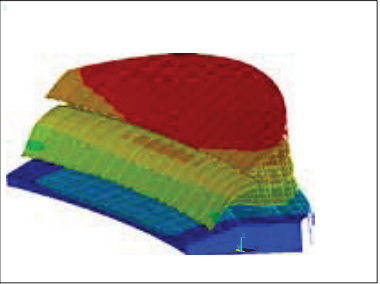
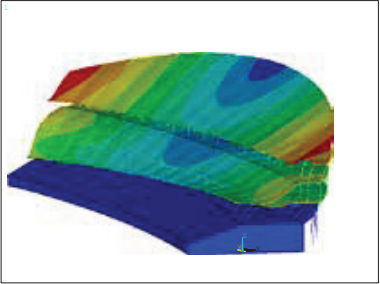
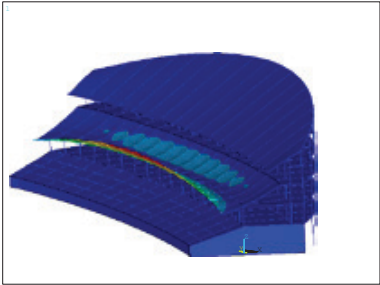
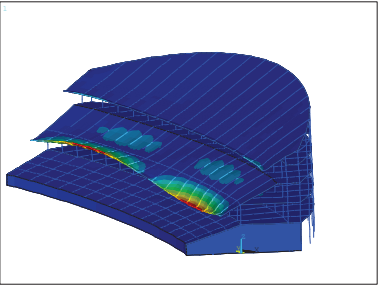
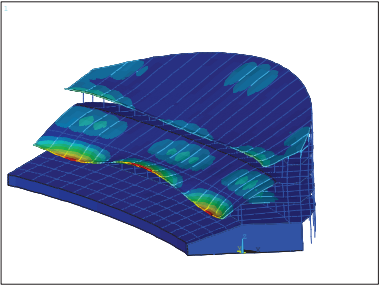
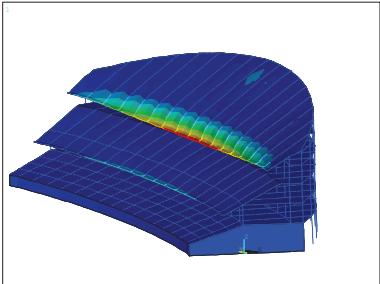
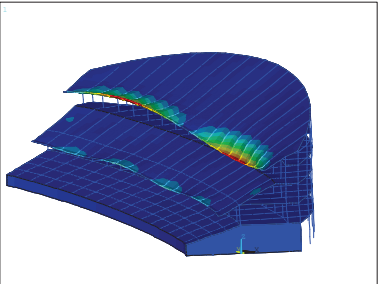
		
<p>Global Side-to-Side Sway Mode f = 1.85 Hz</p>	<p>Global Fore-and-Aft Mode f = 2.00 Hz</p>	<p>Global Fore-and-Aft Mode f = 2.51 Hz</p>
		
<p>Middle Cantilever Mode f = 6.22 Hz</p>	<p>Middle Cantilever Mode f = 6.52 Hz</p>	<p>Middle Cantilever Mode f = 6.62 Hz</p>
		
<p>Upper Cantilever Mode f = 7.19 Hz</p>	<p>Upper Cantilever Mode f = 7.29 Hz</p>	

Examining first the global modes, it can be seen that the first side-to-side sway mode predicted by the FE model occurred at 1.85 Hz, compared with 3.22 Hz that was measured. This is a significant discrepancy that is most likely to be caused by the presence of non-structural walls around the perimeter of the stadium. The pre-test modelling had already demonstrated the very high significance of these walls. The first two global fore-and-aft modes occurred at 2.00 Hz and 2.51 Hz, compared with 2.36 Hz and 2.38 Hz that was predicted. This is a reasonable correlation but clearly some updating of the model is required to match these frequencies. One of the most significant omissions from the FE model is the presence of the roof structure, as the additional mass of the roof is likely to reduce the global natural frequencies. Again, the presence of non-structural blockwork walls would affect these modes significantly.

Both the middle and upper cantilever modes occurred in the model at higher natural frequencies than were measured in practice. Assuming that the mass distribution is more-or-less accurate, there is clearly some additional stiffness in the model compared with the actual structure. This may be due to three reasons. Firstly, the use of the uncracked section properties for the cantilever beams provides an overestimation of the stiffness. Concrete usually cracks whilst in use and hence a reduction in stiffness might be appropriate here. The second reason is that the seating decks were assumed to be flat rather than stepped, with the potential for the deck to act as a 'flange' to the raker beams. This effect is clearly likely to lead to an overestimation of the stiffness. In addition, the seating decks were modelled as monolithic with the frames. In actuality, this is not the case as mentioned previously. Clearly a further investigation of the connection between the frames and seating deck elements is required. It is also noticeable that the spacing between the cantilever modes in the model is slightly higher than in reality, which may be due to an overestimation of the lateral stiffness of the seating deck elements, which are in fact discontinuous at each frame location. This also requires further investigation.

In due course it is intended to formally correlate the results of the detailed FE modelling with the results from modal testing and also to carry out FE model updating to improve the correlation. The results of this further analysis will be presented in a future paper.

CONCLUDING REMARKS

The ambient and shaker modal testing demonstrated a complex dynamic behaviour of the actual stadium structure. The most important modes in terms of vibration serviceability are those vertical modes that can be excited by dynamic crowd activity, primarily on the cantilevered tiers, and also global modes which might also be excited by crowds.

The pre-test GSA model of a whole stand created at the design phase was sufficient to predict a global sway mode. However, the sensitivity of the model to the presence of a non-structural blockwork wall was very high so there is a clear need to further guidance about how to model similar structures in the future. The post-test 3D model successfully reproduced the measured global modes, with the discrepancies in frequencies likely to be caused by the presence of non-structural elements and the omission of the roof from the model at this stage.

The pre-test 3D 'slice' model of a single frame and cantilevered tier provided a reasonable estimation of the first vertical mode of vibration. However, the modal testing demonstrated a much more complex behaviour of the cantilevers which produced a family of closely-spaced modes. This is common for strongly orthotropic systems and this behaviour cannot be reproduced using a single frame model. The post-test 3D model reproduced this behaviour, although further investigations are required to improve the correlation of the natural frequencies with the test results.

ACKNOWLEDGEMENTS

The authors would like to acknowledge the financial assistance provided by the UK Engineering and Physical Sciences Research Council (EPSRC) through a research grant entitled "Dynamic Behaviour of Stadia Under Human Occupation and Excitation" (Ref: GR/S73761/01). Also, thanks go to the City of Manchester Stadium, for providing access to the test structure.

REFERENCES

1. Reynolds, P. and Pavic, A., "Modal Testing of a Sports Stadium", 20th International Modal Analysis Conference (IMAC XX), Los Angeles, USA, February 2002.
2. Vibrant Technology Inc., ME'scope VES 4.0 Operating Manual Volume 2 – Reference, Scotts Valley, CA, October 2003.
3. Pavic, A., Yu, C. H., Brownjohn, J. M. W. and Reynolds, P. "Verification of the existence of human-induced horizontal forces due to vertical jumping", 20th International Modal Analysis Conference (IMAC XX), Los Angeles, USA, February 2002.
4. Brincker, R., Zhang, L. and Andersen, P., "Modal identification from ambient responses using frequency domain decomposition," 18th International Modal Analysis Conference (IMAC XVIII), San Antonio, Texas, USA, pp. 625-630, February 7-10, 2000.