

# Compos

Version 8.3

*Oasys*

## Oasys Ltd

---

13 Fitzroy Street  
London  
W1T 4BQ  
Telephone: +44 (0) 20 7755 3302  
Facsimile: +44 (0) 20 7755 3720

Central Square  
Forth Street  
Newcastle Upon Tyne  
NE1 3PL  
Telephone: +44 (0) 191 238 7559  
Facsimile: +44 (0) 191 238 7555

e-mail: [oasys@arup.com](mailto:oasys@arup.com)  
Website: <http://www.oasys-software.com/>

# Oasys Compos

© Oasys Ltd. 2011

All rights reserved. No parts of this work may be reproduced in any form or by any means - graphic, electronic, or mechanical, including photocopying, recording, taping, or information storage and retrieval systems - without the written permission of the publisher.

Products that are referred to in this document may be either trademarks and/or registered trademarks of the respective owners. The publisher and the author make no claim to these trademarks.

While every precaution has been taken in the preparation of this document, the publisher and the author assume no responsibility for errors or omissions, or for damages resulting from the use of information contained in this document or from the use of programs and source code that may accompany it. In no event shall the publisher and the author be liable for any loss of profit or any other commercial damage caused or alleged to have been caused directly or indirectly by this document.

This document has been created to provide a guide for the use of the software. It does not provide engineering advice, nor is it a substitute for the use of standard references. The user is deemed to be conversant with standard engineering terms and codes of practice. It is the users responsibility to validate the program for the proposed design use and to select suitable input data.

Printed: November 2011

# Table of Contents

<b>Part I About Compos</b>	<b>2</b>
1 Overview .....	2
2 Analysis and Design Features .....	2
3 Compos Program Features .....	3
4 Validation .....	4
<b>Part II Using Compos</b>	<b>6</b>
1 Starting Compos .....	6
Job Titles Window .....	7
Typical Compos Window .....	9
Data Manager .....	9
Open Compos 7.4 data file .....	10
Import Members .....	10
2 Setting up preferences .....	10
Input Data .....	11
Output .....	11
Units .....	11
Miscellaneous .....	11
3D Graphic Operations .....	11
Advanced Features .....	12
3 Creating Members and Groups .....	12
Creating New Group .....	12
Creating New Member .....	13
Member Template .....	14
Program Default Member .....	15
4 Editing Member Properties .....	15
Member Titles .....	16
Design Options .....	16
Design Criteria .....	17
Safety Factors .....	18
Steel Beam .....	20
Restraints .....	21
Concrete Slab .....	22
Reinforcement .....	23
Decking .....	24
Shear Studs .....	25
Web Openings .....	26
Loads .....	27
Floor Responses .....	28
5 Graphic views .....	29
3D graphic view .....	29
2D graphic views .....	30
6 Analysis and Design .....	30

Analysis .....	30
Design .....	31
<b>7 Results and Output .....</b>	<b>32</b>
Text output .....	32
Graphic output .....	33
<b>8 Tools .....</b>	<b>33</b>
Remove empty groups .....	34
Sort in ascending order .....	34
Sort in descending order .....	34
<b>9 Compos Text (ASCII) File .....</b>	<b>34</b>
Compos Text (ASCII) File: keywords .....	35
<b>10 File I/O .....</b>	<b>35</b>
Compos Data File .....	35
Import/Export .....	35
<b>11 Programming Interface .....</b>	<b>35</b>
COM Automation .....	36
COM Export Functions.....	36
COM VBA Example.....	38
COM C++ Example.....	39
<b>Part III Technical notes .....</b>	<b>42</b>
<b>1 Critical Sections .....</b>	<b>42</b>
<b>2 Construction dead load .....</b>	<b>42</b>
<b>3 Longitudinal shear force .....</b>	<b>42</b>
<b>4 Minimum percentage of shear interaction .....</b>	<b>43</b>
<b>5 Moment capacity of slender composite section .....</b>	<b>44</b>
<b>6 Optimal Beam Design .....</b>	<b>45</b>
<b>7 Shear Stud Design .....</b>	<b>46</b>
<b>8 Serviceability Limit State .....</b>	<b>46</b>
<b>9 Tapered steel beam .....</b>	<b>47</b>
<b>10 Ultimate Limit State .....</b>	<b>48</b>
<b>11 Web opening analysis .....</b>	<b>49</b>
<b>12 Web opening effect on deflection .....</b>	<b>49</b>
<b>13 Welding Design .....</b>	<b>50</b>
<b>14 Width and depth of concrete slab .....</b>	<b>50</b>
<b>Part IV Appendices .....</b>	<b>53</b>
<b>1 BS5950 Interpretation by Compos .....</b>	<b>53</b>
Section 1. General .....	53
Section 2. Limit state design .....	53
2.1 General Principles .....	53
2.2 Loading.....	53
2.3 Ultimate Limit States.....	54
2.4 Serviceability Limit States.....	54
Section 3. Materials .....	55
3.1 Structural steel.....	55

3.2 Concrete.....	55
3.3 Reinforcement.....	55
3.4 Shear connectors .....	56
3.5 Profiled steel sheets.....	56
3.6 Concrete flange.....	56
<b>Section 4. Section properties .....</b>	<b>56</b>
4.1 Modular ratio.....	56
4.2 Second Moment of area.....	56
4.3 Elastic section modulus.....	56
4.4 Moment Capacity.....	56
4.5 Limiting proportions of cross sections.....	57
4.6 Effective Breadth of Concrete Flange.....	59
<b>Section 5. Composite beams: Ultimate limit state .....</b>	<b>59</b>
5.1 General.....	60
5.2 Moments in continuous beams.....	60
5.3 Design of members .....	60
5.4 Shear connection.....	60
5.5 Partial shear connection.....	62
5.6 Transverse Reinforcement.....	62
<b>Section 6. Composite beams: Serviceability .....</b>	<b>62</b>
6.1 Deflections .....	63
6.2 Irreversible deformation.....	63
6.3 Cracking.....	63
6.4 Vibration.....	63
<b>Appendix A. Guidance on additional aspects of construction .....</b>	<b>63</b>
<b>Appendix B. Plastic moment capacity .....</b>	<b>63</b>
<b>Appendix C. Classification of webs .....</b>	<b>63</b>
<b>Appendix D. Plastic analysis, general method .....</b>	<b>63</b>
<b>2 EN 1994-1-1:2004 Interpretation .....</b>	<b>64</b>
<b>Section 1. General .....</b>	<b>64</b>
<b>Section 2. Basis of design .....</b>	<b>64</b>
<b>Section 3. Materials .....</b>	<b>64</b>
3.1 Concrete.....	64
3.2 Reinforcing steel.....	65
3.3 Structural steel.....	65
3.4 Connecting devices.....	65
3.5 Profiled steel sheeting.....	66
<b>Section 4. Durability .....</b>	<b>66</b>
<b>Section 5. Structural analysis .....</b>	<b>66</b>
5.1 Structural modeling for analysis.....	66
5.2 Structural stability.....	66
5.3 Imperfections.....	66
5.4 Calculation of action effects .....	66
5.5 Classification of cross-sections.....	67
<b>Section 6: Ultimate limit states .....</b>	<b>67</b>
6.1 Beams .....	67
6.2 Resistances of cross-sections of beams.....	67
6.3 Resistances of cross-sections of beams for buildings with partial encasement.....	68
6.4 Lateral-torsional buckling of composite beams.....	68
6.5 Transverse forces on webs.....	69
6.6 Shear connection.....	69
6.7 Composite columns and composite compression members.....	70
6.8 Fatigue.....	70

---

<b>Section 7. Serviceability limit states</b> .....	<b>70</b>
7.2 Stresses.....	70
7.3 Deformations in buildings .....	70
7.4 Cracking of concrete.....	71
<b>Section 8: Composite joints in frames for buildings</b> .....	<b>71</b>
<b>Section 9: Composite slabs with profiled steel sheeting for buildings</b> .....	<b>71</b>
<b>Appendix A. (Informative) Stiffness of joint components in buildings.</b> .....	<b>71</b>
<b>Appendix B. (Informative) Standard tests</b> .....	<b>71</b>
<b>Appendix C. (Informative) Shrinkage of concrete for composite structures for buildings</b> .....	<b>71</b>
<b>3 SCI P 068 Implementation</b> .....	<b>71</b>
<b>4 SCI P 355 Implementation</b> .....	<b>74</b>
<b>5 NCCI PN-001a GB Implementation</b> .....	<b>78</b>
<b>6 NCCI PN-002a GB Implementation</b> .....	<b>78</b>
<b>7 References</b> .....	<b>79</b>
 <b>Index</b>	 <b>81</b>

# Foreword

This is just another title page  
placed between table of contents  
and topics

# About Compos

**Part**

---

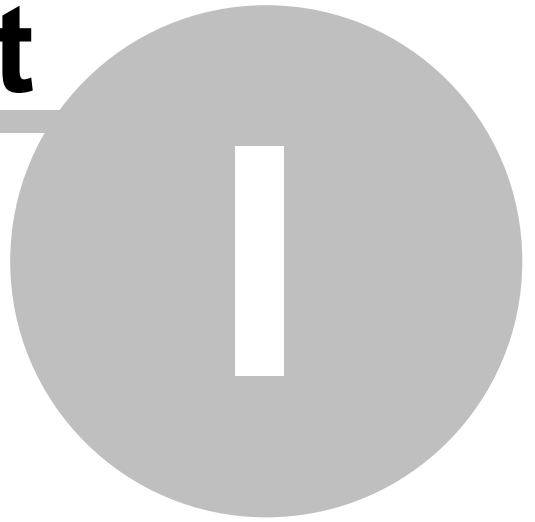

# 1 About Compos

[Overview](#)

[Analysis and Design Features](#)

[Compos program features](#)

[Validation](#)

## 1.1 Overview

Compos is a Windows program for the analysis and design of single span simply supported steel-concrete composite beams. The composite beam is composed of "I" shape steel beam and in-situ metal decking concrete slab or solid concrete slab which are connected by shear connectors. The typical section of the composite beam is as shown below.

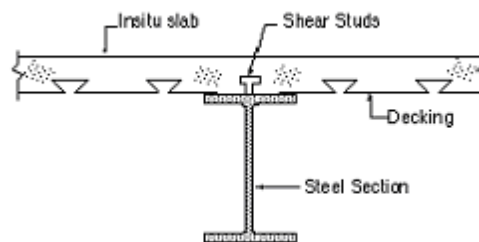

## 1.2 Analysis and Design Features

### ULS and SLS analysis

Composite beam analysis for both construction and final stages.

### Design codes for composite beam analysis and design

The following design codes are supported by Compos.

Composite beam analysis and design	Construction stage analysis
BS5950 Part 3.1 1990 (Superseded)	BS5950 part 1:2000
BS5950 Part 3.1 1990+A1:2010	BS5950 part 1:2000
BS EN 1994-1-1:2004 Eurocode 4	BS EN 1993-1-1:2005 Eurocode 3

### Steel beam design

Compos can check the steel beam in accordance with corresponding steel design code as shown in the above table for the ULS loads in the construction stage. Compos uses the GSA steel checker for checks related to the steel design.

### Capacity check

Compos can check the capacity of composite beams against the imposed loads to see whether it meets all the code requirements.

### Design

If doing design, Compos can automatically choose a steel beam section from the section database

to meet the code and user specified requirements.

### **Load types**

Load types available in Compos are Area UDL, Linear UDL, Line, Patch and Point loads etc.

### **Safety factors**

User defined load factors and user defined material partial safety factors are possible in Compos

### **Construction methods**

Both propped and unpropped construction methods are supported by Compos.

### **Automatic stud design**

Compos can design the quantity and layout of shear studs if required.

### **Shear studs**

Both standard and user defined shear studs can be used.

### **Metal decking profiles**

Both catalogue and user defined metal decking profiles can be used in Compos.

### **Steel beam sections**

Both catalogue and user defined steel beam section can be used. Catalogue sections include British, European, American and Australian catalogue sections.

### **Variable steel beam section**

The steel beam can be tapered or varied along the beam.

### **Variable concrete slab**

The width and depth of concrete slab are variable along the beam.

### **Web Openings**

Rectangular and circular web openings as well as notches at the ends with or without stiffeners can be specified. Analysis of web openings is in accordance with the Steel Construction Institute Publication 068 "Design for Openings in the webs of Composite beams".

### **Foot-fall induced floor vibration analysis**

Foot-fall induced floor vibration (response factor) analysis for rectangular composite floor bay is included.

## **1.3 Compos Program Features**

### **Units**

Compos allows the user to work in any preferred units. Several standard sets of units are provided for easy set up of the preferred unit.

### **Data Input**

All the input data for a composite beam are integrated into a wizard with a number of pages relating to each of the features (e.g. steel beam, concrete slab etc) of the composite beam. More than one composite beam (Member) can be included in a single Compos file. New members can be created

from a previously created member template or by existing members or by using the data defaults.

### **Analysis**

When an analysis is requested the data are checked for data errors and consistency. If input data errors are detected, a report is prepared and the analysis will be abandoned, otherwise the analysis will proceed with the progress being reported to the screen throughout the analysis. Analysis can be carried out for a single member or a selected number of members or all the members in selected groups.

### **Design**

When a design is requested Compos will try to find the most suitable steel section which will make the composite beam meet all the code and user specified requirements. The criterion used to select the most suitable section can be either minimum depth or minimum weight of the steel beam.

### **Output**

Outputs are in tabular form or graphic diagrams. The numerical format in the output may be specified in terms of either significant figures or decimal places.

### **Graphics**

The 3D graphics in Compos is designed to give users confidence in the composite beam to be designed. Each of the components (e.g. steel beam and concrete slab etc) can be switched on and off individually on the graphic view to make it easier to view all or some of the individual components.

### **Text Output**

Text summary outputs are available in both text only format and text & graphic format.

### **Tabular Output**

Most of the results can also be viewed in tabular format. The available tabular outputs include detailed results, stud layout, transverse reinforcement layout and web opening results.

### **Links to Spreadsheets**

Data from tables can be transferred to and from spreadsheets using the standard cut and paste facilities.

### **Text data file**

In addition to the normal binary data file, Compos also supports a text data file (ASCII data file). The text data file can be written in tab-separated format and CSV format, enabling Compos data to be prepared in a spreadsheet.

## **1.4 Validation**

The program has been passed through an automatic test procedure which compares results with benchmark results for over 100 members. The benchmark results have been calibrated against hand calculations. However, users should also check the validity of the results to make sure they meet all the code requirements.

# Using Compos

**Part**

---



## 2 Using Compos

This chapter introduces the use of Compos and covers the following sections:

[Starting Compos](#)  
[Setting up preferences](#)  
[Creating members and groups](#)  
[Editing member properties](#)  
[Graphic view of input data](#)  
[Analysis and Design](#)  
[Results and Output](#)  
[Tools](#)

### 2.1 Starting Compos

On starting Compos, the welcome dialog box as shown below will be displayed if it has not been switched off. Various options are available on this dialog box to start using Compos. The welcome dialog box can be switched off by unchecking the "Show this dialog on StartUp" box. This dialog box can also be switched on and off from page "Miscellaneous" of Compos preferences from Tools menu.

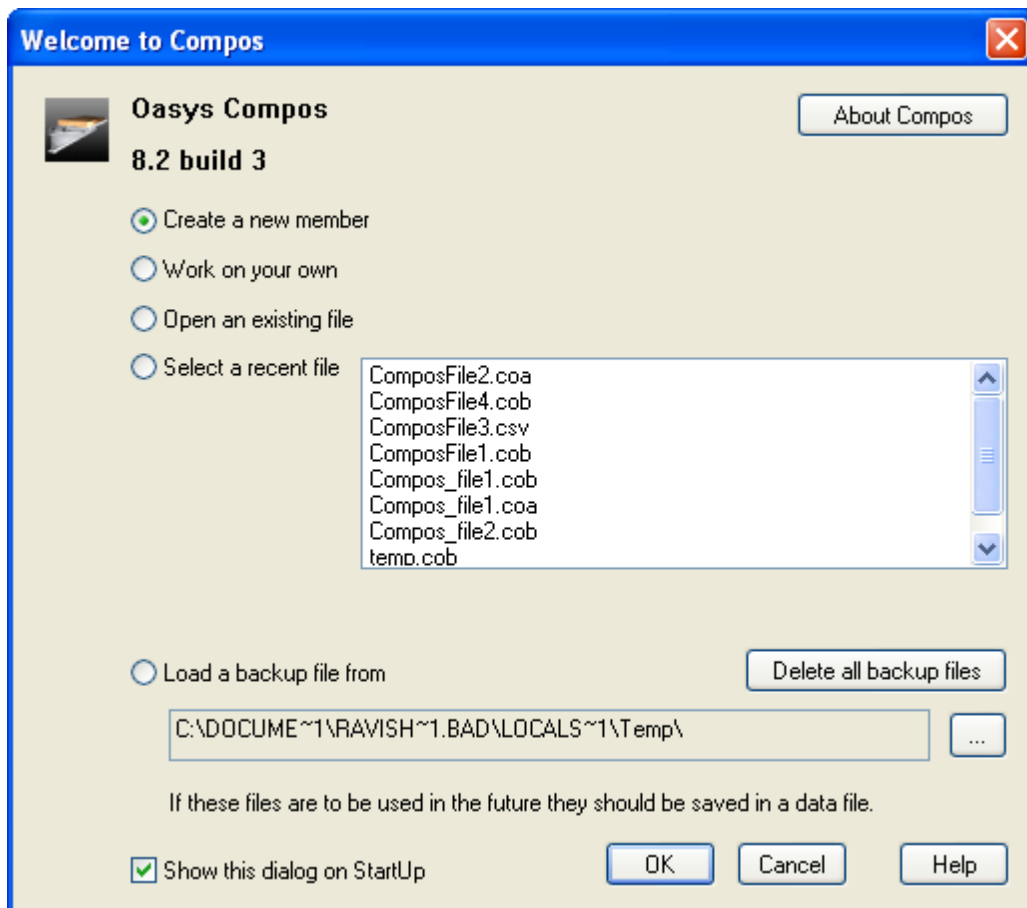

*Welcome Window*

After closing the welcome dialog box or if the welcome dialog box has been switched off, a blank Compos Window as shown below will be opened.

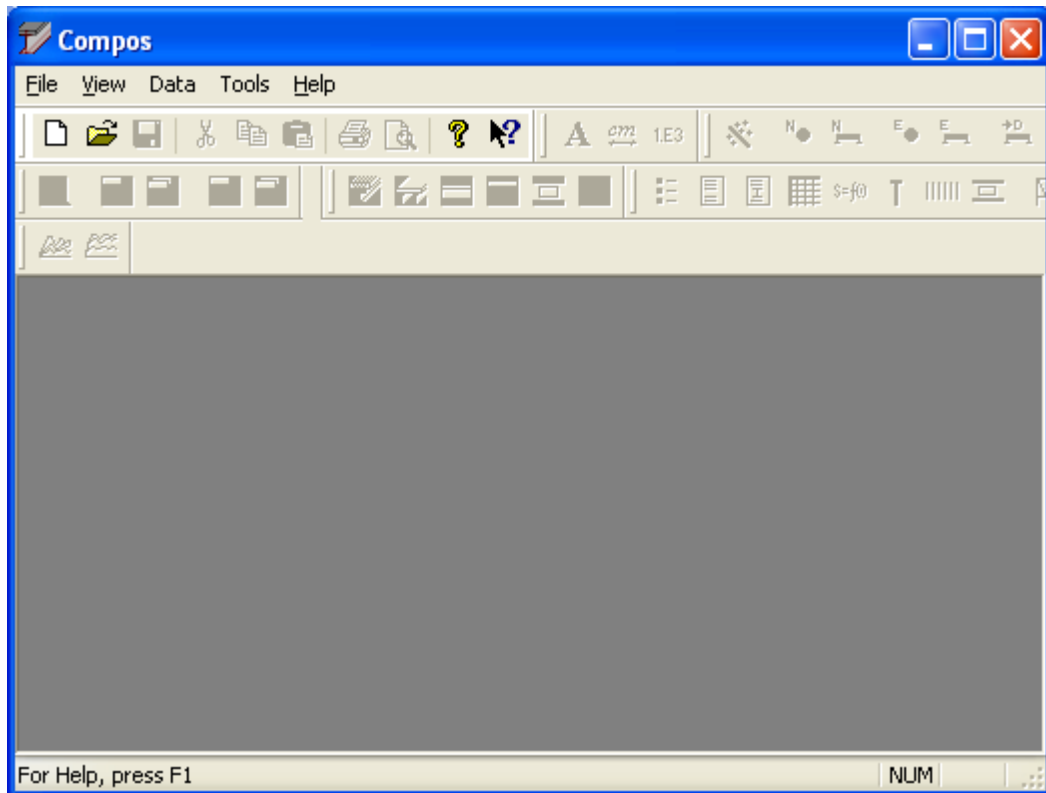

A new Compos file can be created through "File | New" button. An existing Compos file can be opened through "File | Open" button.

**More:**

[Job Titles Window](#)

[Typical Compos Window](#)

[Data Manager](#)

[Open Compos 7.4 data file](#)

[Import members](#)

### 2.1.1 Job Titles Window

When creating a new Compos file, the Job Titles dialog box as shown below will appear. The Job Titles dialog box contains information relating to the file e.g. the date, job title, notes etc. It is optional to fill the entries to proceed. Click OK to close this window and a blank Compos file will be created. The Job Titles dialog box is always available for viewing and/or editing through menu item "Data | Titles".

**Job Titles** ✖

<u>J</u> ob Number	<u>I</u> nitials	<u>E</u> dit Date	Company Info...
<input type="text"/>	<input type="text"/>	07-Jun-2005	

Job Title

Subtitle

Heading

Notes

## 2.1.2 Typical Compos Window

The typical Compos window is as shown below. It includes "[Data Manager](#)", "[Member Property wizard](#)" and "[3D Graphic View](#)". More views can be opened simultaneously on the Compos Window.

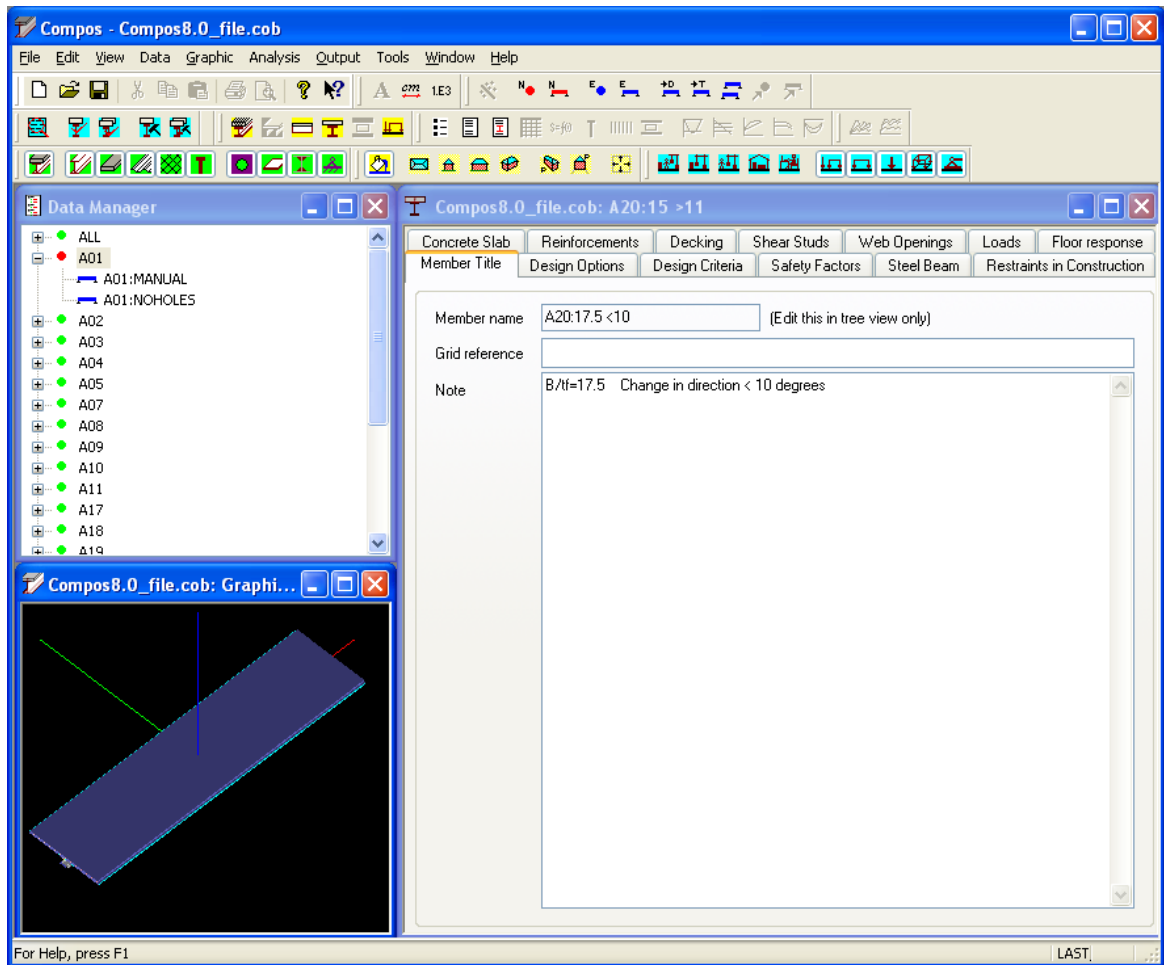

## 2.1.3 Data Manager

A single Compos file can contain more than one composite beam (member) which can be organized into different groups. A group is simply a collection of members. The groups and members are presented in the Data Manager as shown below. Closing the Data Manager window will close the current Compos file. The Data Manager window always has a group named "ALL" which contains all the members in the Compos file. Group "ALL" cannot be renamed or deleted. A member can belong to more than one group. Adding an existing member to a group does not create a new member, but just adds the name of that member to the group. Deleting a member from a group rather than group ALL does not delete the member from the file. Only deleting a member from group "ALL" will delete the member from the file.

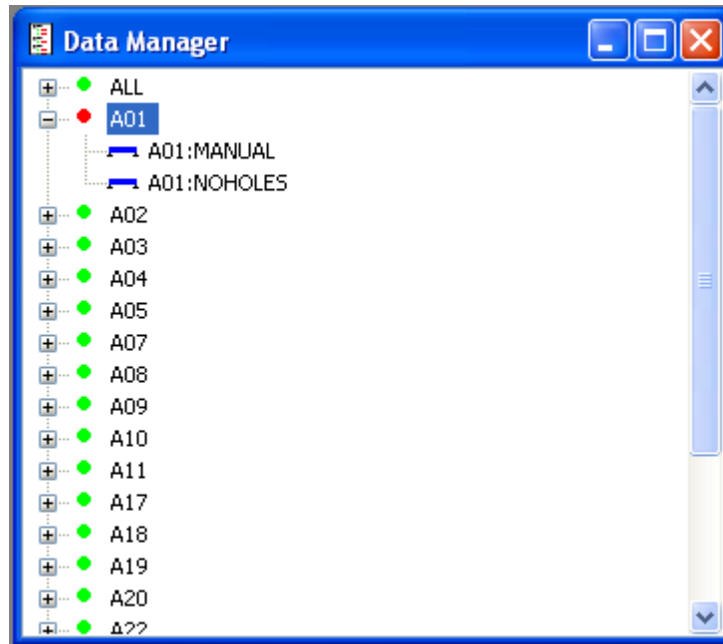

### 2.1.4 Open Compos 7.4 data file

A Compos 7.4 data file (\*.cow) can be opened by selecting file type of "Version 7 files (\*.cow)" on the file open dialog box.

### 2.1.5 Import Members

Members in another Compos file can be merged to the currently opened Compos file. This can be done through menu item "File | Import Member(s)". If there are duplicated members between the two files, options will be given to keep the current members or to replace the current members by the imported member. Selected members or groups can also be exported to a file, so they can be opened or imported by other Compos file.

## 2.2 Setting up preferences

Preferences are those data or states that Compos will use as defaults in the current and future sessions. Preferences are not saved with Compos data file. The preferences are divided into the following categories

[Input data](#)

[Output](#)

[Units](#)

[Miscellaneous](#)

[3D Graphic Operations](#)

[Advanced features](#)

### 2.2.1 Input Data

Preferences for input data:

- Default catalogue of steel beam sections
- Default catalogue of metal decking profiles
- The maximum distance of the critical sections (section to be checked for its capacity). It can be an absolute distance or as a percentage of the beam span.
- Maximum allowable number of stud zones, the highest number allowed is 3 and the lowest is 1. If uniform stud layout for the whole beam is preferred, it can be achieved by setting this to 1.

### 2.2.2 Output

Preferences for output data:

- Numerical format of output
- Pseudo zero - a small number which Compos will take as zero.

### 2.2.3 Units

Preferences for units to be used by Compos:

4 standard sets of units are available and they can be quickly set by clicking the relevant button.

### 2.2.4 Miscellaneous

Preferences of miscellaneous settings:

- Maximum number of message to be displayed on report view
- Member property wizard to be resizable or not
- Timed backup interval. If the interval is zero, there will be no timed backup.
- Options of ComboBox style in the tables of Member property wizard. If checked, the drop-down list will be available at the ComboBox.
- Startup options. Enable or disable version checking; Show or hide welcome dialog box.
- Company Info
- Temporary file and database file locations
- Page setup for printing

### 2.2.5 3D Graphic Operations

Preferences for 3D Graphic Operations:

- Auto-scale margin
- Mouse operations on the 3D graphic view
- Keyboard operations on the graphic view
- Method of drawing area loads on 3D graphic view

## 2.2.6 Advanced Features

Preferences for advanced features:

- Whether to carry out foot-fall induced floor vibration analysis. If this is disabled, "Floor responses" page will not be available on the Member Property wizard.
- Increment of walking frequency which will be used to determine the points of walking frequency for which the floor responses will be evaluated. The points of walking frequency are determined from the lowest walking frequency and increased continuously by the increment until the highest walking frequency.
- Number of response positions along the half length of the cross direction (perpendicular to the composite beam direction) of the floor. The floor responses will be given only for those points which are evenly distributed from one end to the centre of the floor.
- Method of calculation beam frequency. If not using Rayleigh's method, the beam deflection shape will be taken as the mode shape to evaluate the beam frequency using the energy method.

## 2.3 Creating Members and Groups

After creating a new Compos file, there is only one default group named "ALL" and there are no members (Composite beams) in the file. New members or groups can be easily created through menu items or Toolbar buttons. The following sections explain how to create new groups and members.

[Creating New Group](#)

[Creating New Member](#)

[Program Default Member](#)

[Member Template](#)

### 2.3.1 Creating New Group

The default group "ALL" is always available. It holds all the members in the file; it cannot be deleted. New groups can be created through menu item "Data | New Group" or by clicking the relevant toolbar button. After this, the Group Properties dialog box as shown below will appear. A default group name is always given; it can be changed if required. Click OK to create the group or click Cancel to abandon the operation.

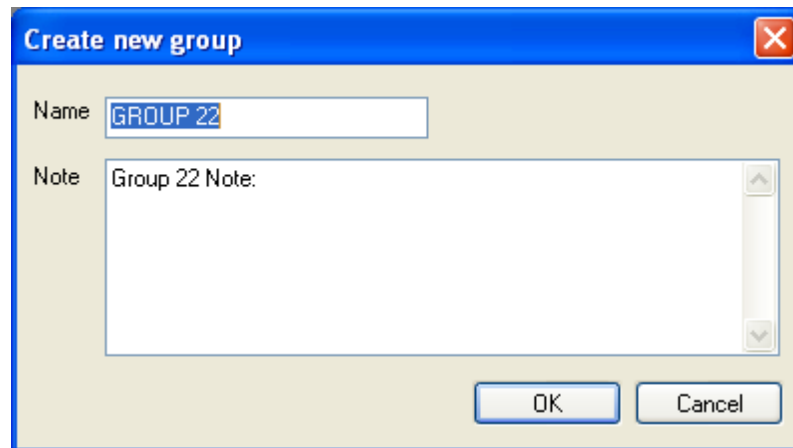

The group dialog box for existing groups can be opened through the menu item "Data | Group Properties" or by double clicking the group name on the Data Manager.

### 2.3.2 Creating New Member

New Members can be created through menu item "Data | New Member" or by clicking the relevant toolbar button. After this, the Add New Member dialog box as shown below will appear. A default member name is always given and it can be changed if required. Select the required method for member creation and click "Add" to add the member or click "Cancel" to abandon the operation.

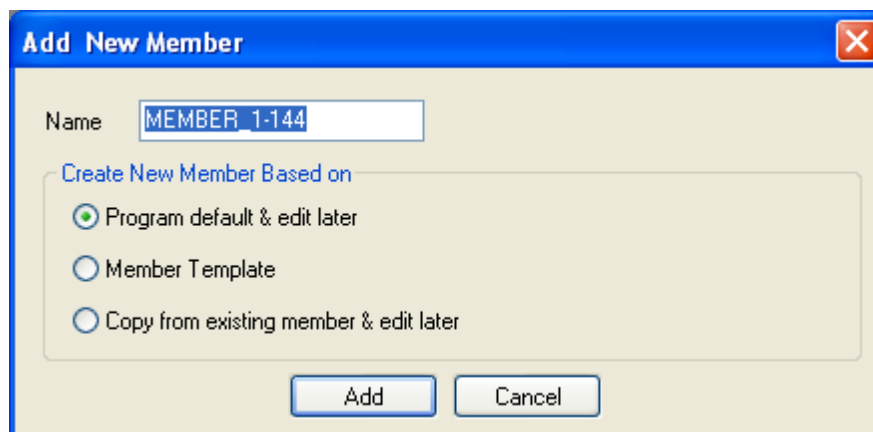

After clicking the "Add" button, the following dialog box will be given for selecting groups to add this member to. A new group can also be created within this dialog box by clicking the "Create new group" button.

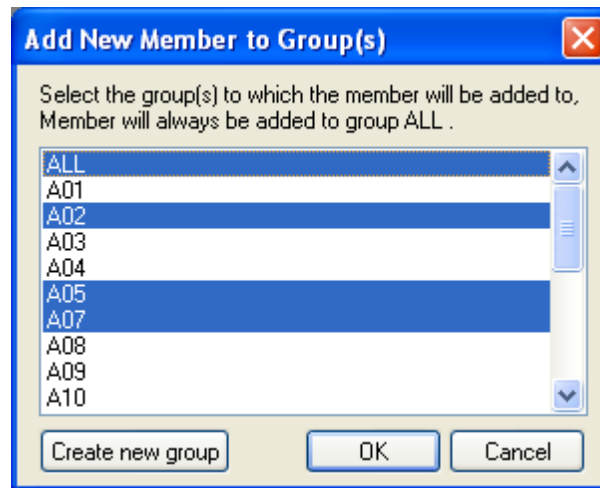

A new member can also be easily created by duplicating the current Member through the menu item "Data | Duplicate current member" or by clicking the relevant toolbar button.

**More:**

[Member Template](#)

[Program Default Member](#)

### 2.3.3 Member Template

Creating a member using a template is likely to be the most common method. Here the user is presented with a series of input screen where the appropriate data can be entered. The template defines the default entries and the wizard pages that will be presented when creating a new member using Template. More than one template can be created and used. A template can be created base on the current member through the menu item "Data | Save as template". After clicking "Save as template", the following dialog box will appear. Select the wizard pages that, when creating a member from template, are presented for editing. Click OK to save the template to the selected folder on the computer for future use.

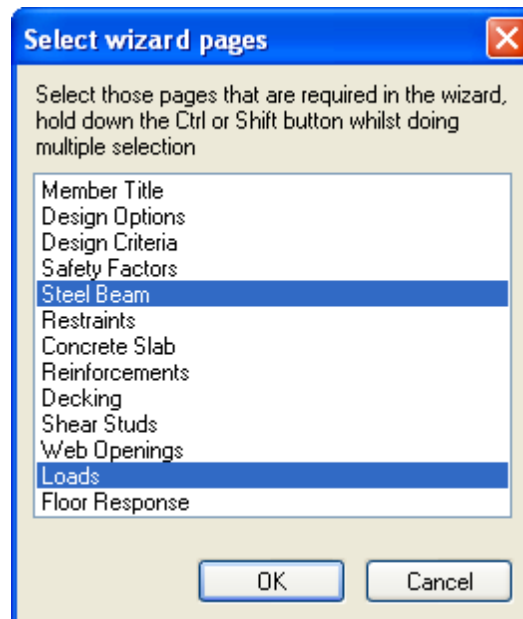

### 2.3.4 Program Default Member

A "Program default" member is a member that can be copied to create a new member and edit it later. The default member properties can be reset by the current member through menu item "Data | Set default member properties". The default member can also be edited through menu item "Data | Set default member properties". Only one default member exists in a Compos file; editing the default member properties will overwrite the previous default member properties, but will not affect the properties of the members derived from the default.

## 2.4 Editing Member Properties

To enter properties for the new member or edit properties for an existing member, the Member Property wizard needs to be opened through menu item "Data | Member properties", or by double clicking the member name on the [Data Manager](#) or by clicking the relevant Toolbar button. The property wizard has the following pages corresponding to each group of properties of a composite beam.

[Member Titles](#)

[Design Options](#)

[Design Criteria](#)

[Safety Factors](#)

[Steel Beam](#)

[Restraints in Construction](#)

[Concrete Slab](#)

[Reinforcements](#)

[Decking](#)

[Shear Studs](#)

[Web Openings](#)

[Loads](#)

[Floor Responses](#)

### 2.4.1 Member Titles

Member Property: Member Titles.

This page is for entering notes etc for the member. The member name is shown on this page, but it cannot be edited. The member name can only be edited from [Data Manager](#). To change a member name, highlight the member name on Data Manager and then through menu item "Edit | Rename" or through right click popup menu item "Rename". Grid reference and note for the member are optional.

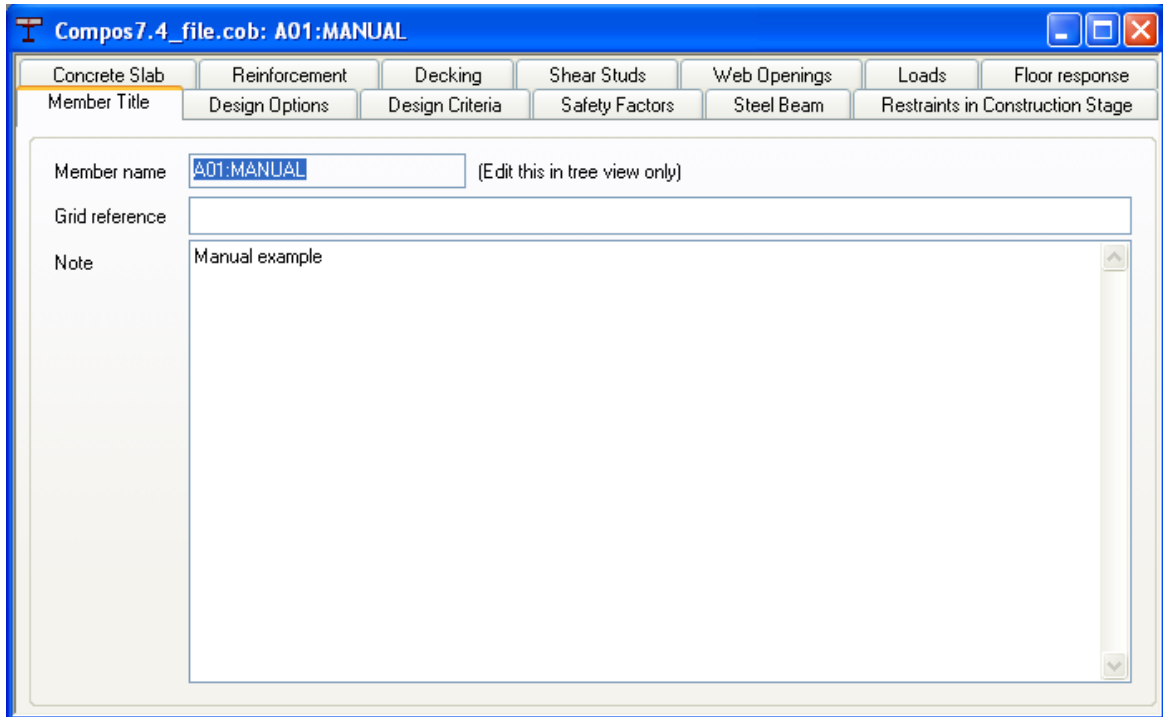

### 2.4.2 Design Options

Member Property: Design Options

- Design code - the design code to be used for analysis and design of this member
- Construction method - either propped or unpropped
- Include steel beam weight or not in the analysis - if included, steel beam weight will be added to "construction dead load" as well as "final dead load"
- Include slab weight or not in the analysis - if included, slab weight will be added to "construction dead load" as well as "final dead load"
- Include thin-flange sections or not in the selection of steel beam section on design (it will not be used in analysis).
- Whether to consider shear deflection in deflection calculation

**Compos1: MEMBER-1**

Reinforcement | **Decking** | Shear Studs | Web Openings | Loads | Floor response

Member Title | **Design Options** | Design Criteria | Safety Factors | Steel Beam | Restraints | Concrete Slab

**Code of Practice**

Design Code: EN1994-1-1:2004

Country Name: United Kingdom

**Design Option**

Construction Method:  Propped  Unpropped

Include steel beam weight  Include concrete slab weight

Include thin-flange sections  Consider shear deflection

**EN1994-1-1:2004 Code Options**

**Options**

Consider shrinkage deflection

Ignore if the ratio of length to depth is less than 20 for normal weight concrete

Use approximate modular ratios [ 5.2.2 (11)]

**Cement Type**

Cement class S  Cement class N  Cement class R

**Creep and Shrinkage parameter**

	Long term	Shrinkage
Creep multiplier	1.1	0.55
Age of concrete when load applied in days	28	1
Age of concrete in days	36500	36500
Relative humidity	50 %	50 %

### EN 1994-1-1:2004 Design options:

These options are only available for EN 1994-1-1:2004 design.

- Consider shrinkage deflection - If this option is selected shrinkage deflection will be included.
- Ignore shrinkage deflection if the ratio of length to depth is less than 20 and the concrete is normal weight concrete
- Use approximate modular ratios - Approximate E ratios are used in accordance with 5.2.2 (11) of EN 1994-1-1:2004
- Cement type - Cement type used in concrete
- Creep multiplier - creep multiplier used for calculating E ratio for long term and shrinkage (see clause 5.4.2.2 of EN 1994-1-1:2004)
- Age of concrete when load applied, Age of concrete and Relative humidity will be used to calculate the creep coefficient

### 2.4.3 Design Criteria

Member Property: Design Criteria

- Deflection limits - either absolute or relative to beam span or both can be specified.
- Whether to calculate natural frequency of the beam - if unchecked, natural frequency will not be calculated.

- Minimum frequency required - if the actual frequency is lower than this, a warning will be given.
- Percentage of final stage dead loads to be converted to mass in frequency and floor response calculation.
- Percentage of final stage live loads to be converted to mass in frequency and floor response calculation.
- Minimum and maximum depth of steel beam to be used in design - Compos will not choose a steel beam outside this range in design. It is not used in analysis.
- Minimum and maximum width of steel beam to be used in design - Compos will not choose a steel beam outside this range in design. It is not used in analysis.
- Selection criteria of steel beam in design - it can be based on minimum weight or minimum depth of the steel beam.
- Steel beam section types to be used in the selection of steel beam in design - only the sections in the selected section types will be used in the sections of steel beam in design. This does not have any effect in analysis as steel beam section will not be changed in analysis.

The screenshot shows the 'Design Criteria' tab in the Oasys Compos software. The interface is divided into several sections:

- Deflection Limits:** A table with columns for 'Absolute deflection [m]' and 'Deflection/span ratio'.
 

	Absolute deflection [m]	Deflection/span ratio
Construction dead load	<input checked="" type="checkbox"/> 0.1	<input type="checkbox"/> 1/0
Additional dead load	<input checked="" type="checkbox"/> 0.05	<input type="checkbox"/> 1/0
Final live load	<input type="checkbox"/> 0	<input checked="" type="checkbox"/> 1/360
Total loads	<input checked="" type="checkbox"/> 0.2	<input type="checkbox"/> 1/0
Post-construction (total minus const. dead)	<input type="checkbox"/> 0	<input type="checkbox"/> 1/0
- Natural Frequency:**
  - To be considered in design and analysis
  - Minimum frequency required: 5 Hz
  - % of dead load to be included in frequency calculation: 100 %
  - % of live load to be included in frequency calculation: 10 %
- Beam Depth [m] Used in Design:**

	Depth	Width
Minimum	0	0
Maximum	1.0	1.0
- Selection Criterion Used in Design:**
  - Minimum weight
  - Minimum depth
- Section type(s) to be used in design:** A list box containing various steel beam and column sections, with 'British: Universal Beams (BS4: Part 1: 1993)' selected.

## 2.4.4 Safety Factors

### Partial safety factors for BS5950

Member Property: Safety Factors

- If "User defined" check box is unchecked, the safety factors given by the design code will be used, so the safety factors cannot be edited.
- If "User defined" check box is checked, each of the individual safety factors can be edited and they will be used in the analysis and design.

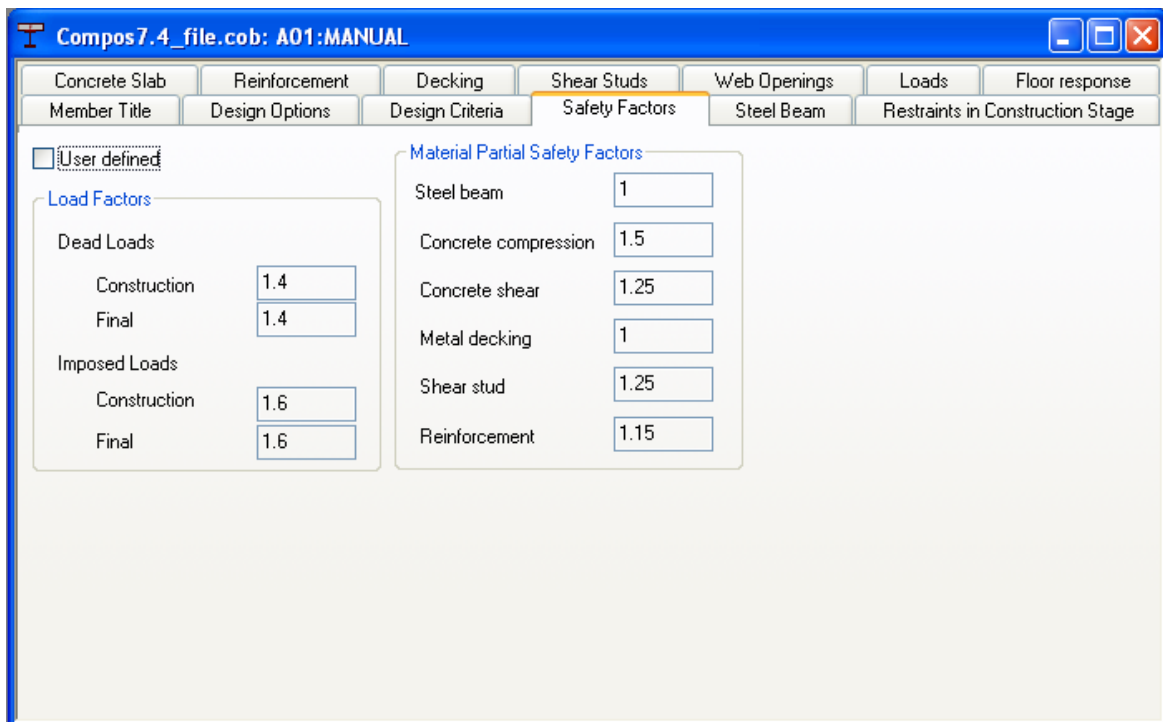

## Partial safety factors for EN 1994-1-1:2004

### EN 1990:2002 load combinations

- if "Use equation 6.10" is selected load combination specified in equation 6.10 of EN 1990:2002 will be used in the analysis.
- if "Use worse of 6.10a and 6.10b" is selected worse value obtained from load combinations specified in equations 6.10a 6.10b will be used. Compos assumes that this load combination will not be used for storage structures.
- if "User defined" option is selected load combination partial safety factors can be edited and they will be used in the analysis.

### Material Partial Safety Factors

- If "User defined" check box is unchecked, the partial safety factors given by the design code will be used, so the factors cannot be edited.
- If "User defined" check box is checked, each of the individual partial safety factor can be edited and they will be used in the design.

**EN 1990:2002 load combinations**

Use equation 6.10  
 Use worse of 6.10a and 6.10b (not applicable for storage structures)  
 User defined

	Construction	Final
$\xi$	1	1
$\Psi_0$	1	1
$\gamma_G$	1.35	1.35
$\gamma_Q$	1.5	1.5

**Material Partial Safety Factors**

User defined

$\gamma_{M0}$	1
$\gamma_{M1}$	1
$\gamma_{M2}$	1.1
$\gamma_C$	1.5
$\gamma_{Deck}$	1
$\gamma_{vs}$	1.25
$\gamma_S$	1.15

## 2.4.5 Steel Beam

Member Property: Steel Beam

- Steel beam material, it can be standard or user defined
- Number of spans. It is limited to 1 in this version. Continuous beam with more than one span will be available in the future version of the program.
- Span length - the length of the composite beam.
- Welding material will be active if a non-catalogue section is defined
- Different sections can be defined at different positions along the beam. Between these defined sections, the section can be tapered or uniform. The positions of the sections are the distance of the section from left hand side of the beam. If the tapered option is "No", the section will be constant until the next defined section or the end of the beam. If the tapered option is "Yes", the section will be tapered from current section to the next defined section. If there is no next defined section, the section will be constant until the end of the beam. The section can be edited using section wizard which can be activated by double clicking the relevant row, right click the row and choose wizard or through the wizard Toolbar. The section can also be edited on the table either by specifying the "Section description" or the section dimensions. For catalogue sections, only the "Section description" can be edited.
- Apply reduction factor for plastic moment capacity - this option is only available for EN 1994-1-1:2004 design. This is disabled for standard steel grades and enabled for user defined steel grades. This option is used when calculating the plastic resistance of composite beam (see [6.2.1.2](#) of EN 1994-1-1:2004 for more details)

Compos1: MEMBER-1

Reinforcement | Decking | Shear Studs | Web Openings | Loads | Floor response

Member Title | Design Options | Design Criteria | Safety Factors | Steel Beam | Restraints | Concrete Slab

Beam Steel Material

Standard S275 (EN) fy 275 [N/mm<sup>2</sup>] Density 7.85 [t/m<sup>3</sup>]

User defined E 210000 [N/mm<sup>2</sup>]  Apply reduction factor for plastic moment capacity (6.2.1.2 (2))

Welding material grade for girder: Grade 35

Span Number & Length: Number of spans (1 only in this version) 1, Span 1 [m] 9

Beam Section (double click a row to activate section Wizard)

	Position (from left) [m], [%]	Section description	Depth [cm]	Top flange		Bottom flange		Web thick [cm]
				Width [cm]	Thick [cm]	Width [cm]	Thick [cm]	
Defaults	0	STD I 600 200 15 25	60	20	2.5	20	2.5	1.5
1	0	STD I 600. 200. 15. 25.	60	20	2.5	20	2.5	1.5
2								

## 2.4.6 Restraints

Member Property: Restraints in Construction Stage

The restraints apply to the steel beam only and are only effective for construction stage analysis and design. They are ignored by final stage analysis and design

- Top flange laterally restrained - Select this option if top flange of steel beam is effectively restrained in horizontal direction in construction stage. If top flange is restrained, other restraints become unnecessary and they will be disabled.
- Top flange is free to move laterally - If top flange is not effectively restrained, this option should be used and point restraints can be specified as shown below.
- Take secondary member as intermediate restraint - secondary member is the composite beam acting on this member as "Member [Loads](#)". Check this box if the secondary beam has effective restraints to this member. If the current member has no member loads, this check box has no effect on the restraint condition of the beam
- Both ends of the beam are assumed to be restrained by default. If there are no other intermediate restraints, choose button "No intermediate point restraints", otherwise choose the relevant button if intermediate restraints are available and evenly distributed.
- If there are no end restraints or the intermediate restraints are not evenly distributed, choose the button "User defined restraints" and edit the positions of the restraints on the table.

Member Property: Restraints in Final Stage

The restraints apply to the composite beam if there is a 'no stud' zone.

- No stud zone is laterally restrained - Select this option if the 'no stud' zone is effectively restrained in horizontal direction in final stage. If the 'no stud' zone is restrained other restraint options are unnecessary and are disabled.
- Restraining condition in the final stage is similar to the restraints in construction stage as specified above.

**Compos1: MEMBER-1**

Reinforcement | Decking | Shear Studs | Web Openings | Loads | Floor response  
 Member Title | Design Options | Design Criteria | Safety Factors | Steel Beam | Restraints | Concrete Slab

**Continuous restraints at construction stage**

Top flange laterally restrained       Top flange is free to move laterally

**Point restraints at construction stage**

Take secondary member as intermediate restraint

No intermediate point restraints.  
 One mid-span point restraint.  
 Two intermediate point restraints at 1/3 and 2/3 points.  
 Three intermediate point restraints at 1/4, 1/2 and 3/4 points.  
 User defined restraints (including both ends)

A	
Sections with construction stage restraint (Distance from left)	
[m], [%]	
Defaults	0
1	0
2	50%
3	100%
4	

**Restraints at final stage**

No stud zone is laterally restrained  
 Take secondary member as intermediate restraint

No intermediate point restraints.  
 One mid-span point restraint.  
 Two intermediate point restraints at 1/3 and 2/3 points.  
 Three intermediate point restraints at 1/4, 1/2 and 3/4 points.  
 User defined restraints (including both ends)

A	
Sections with construction stage restraint (Distance from left)	
[m], [%]	
Defaults	0
1	0
2	50%
3	100%
4	

## 2.4.7 Concrete Slab

Member Property: Concrete Slab

- Concrete grade of slab can be chosen from the drop down ComboBox
- The type of concrete can be either normal weight or light weight
- Concrete dry density can be standard or user defined
- Steel/concrete Young's modulus ratio can be standard or user defined
- Slab width can be specified as available width (in this case, the program will determine the effective width) or effective width

- Slab depth can also be variable if check box "Slab depth is variable" is checked
- The actual width and depth of the slab can be defined on the table. Variable slab width is possible and as many slab sections as required can be defined. Select "Yes" at the last column if the current section of slab is to be tapered to the next section of slab, otherwise the slab section will be constant to the next specified section or to the end of the beam
- Shrinkage strain is only available for EN 1994-1-1:2004 design and it can be user defined or code defined.

**Slab Concrete Material**

Material grade: C30/37

Weight type:  Normal  Light

Density:  Standard  Users

Density Class: 801\_1000

Dry density: 2.4 [t/m<sup>3</sup>]

Steel/Concrete Modular Ratio:

User defined

Short term: 6.24 Vibration: 5.53

Long term: 23.55 Shrinkage: 22.35

Percentage of imposed load acting long term: 33 %

Shrinkage:

User defined

Shrinkage strain: 0.000325

**Slab Dimension**

Type of slab width:  Available widths  Effective widths

Slab depth is variable

	Position (from left)	Overall depth	Left width	Right width	Tapered to next section (depth & width)
	[m], [%]	[cm]	[cm]	[cm]	
Defaults	0	15	100	100	Yes
1	0	13	150	150	Yes
2					

## 2.4.8 Reinforcement

Member Property: Reinforcement

- Mesh reinforcement can be defined and it is used in calculating the shear resistance of the concrete slab in web opening analysis (Step 6 of [SCI publication 068](#)). The transverse direction reinforcement of the mesh is also used in the calculation of slab longitudinal splitting.
- Transverse reinforcement for preventing longitudinal splitting of concrete slab can be defined in three ways. 1. do not provide transverse reinforcement, 2. let the program determine the amount of transverse reinforcement needed, 3. user defined.

Compos1: MEMBER-1

Decking    Shear Studs    Web Openings    Loads    Floor response

Member Title    Design Options    Design Criteria    Safety Factors    Steel Beam    Restraints    Concrete Slab    Reinforcement

Mesh reinforcement

Mesh type: A393    Diameter:    Interval:    Cover: 3.5 [cm]    Longitudinal: 1    20 [cm]    Material grade: 500B     Swap direction    Transverse: 1    20 [cm]

Transverse reinforcement

Material:  Program to choose     User defined

Standard     User defined

Material grade: 500B

Characteristic strength: 500 [N/mm<sup>2</sup>]

	Start (dis from left) [m], [%]	End (dis from left) [m], [%]	Diameter [cm]	Interval [cm]	Cover [cm]
Defaults	0	100%	0.8	10	3.5
1					
2					

## 2.4.9 Decking

Member Property: Decking

- There are three options to define metal decking: 1. Catalogue decking, 2. User defined decking, and 3 no decking (solid slab)
- Decking angle - Decking angle can be defined from -90 to +90 degree Celsius. If the decking is parallel to the beam, the angle is 0 degree; if the decking is perpendicular to the beam, the angle is 90 degree
- Decking is discontinuous across steel beam - check this box if there is a joint of the decking on the beam
- Decking is welded onto the steel beam - If decking is effectively welded onto the steel beam, check this box.
- If catalogue decking is chosen, the dimensions of decking can only be viewed. If it is user defined decking, the dimension of the decking must be defined by the user.

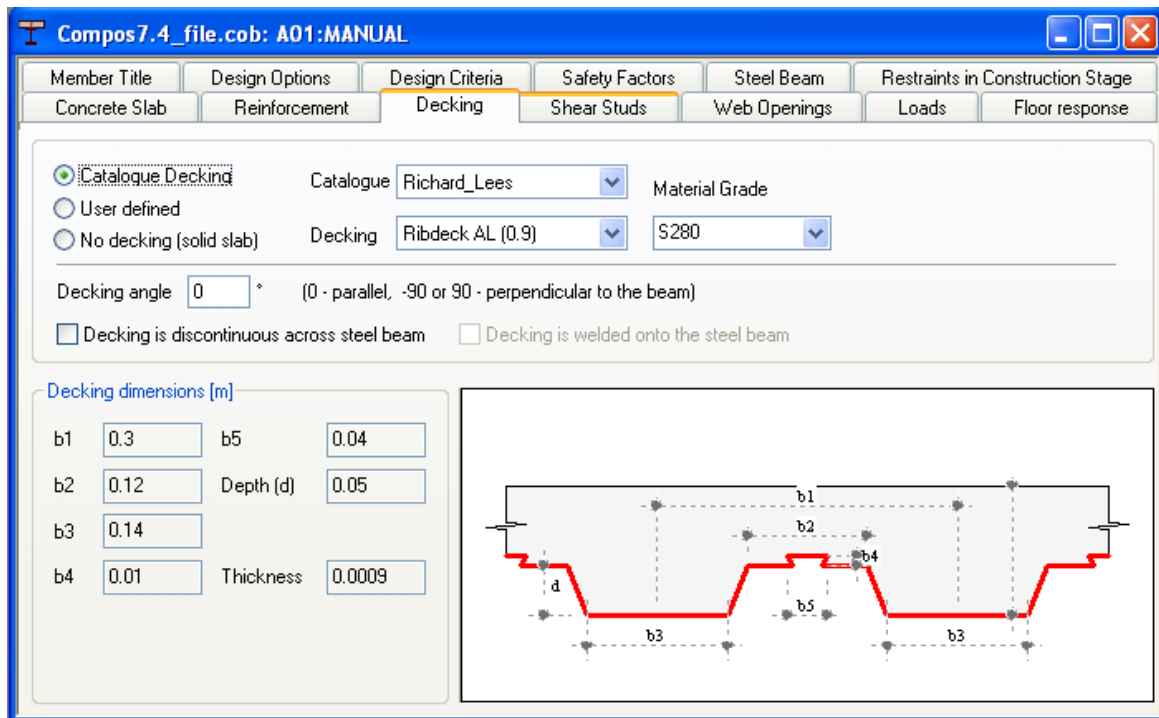

## 2.4.10 Shear Studs

Member Property: Shear Studs

- Standard or user defined shear studs can be used. If user defined stud is selected characteristic strength of the stud need to provided for BS5950 design codes.
- There are 4 choices for arranging shear studs:
  1. Automatic, 100% interaction - the number of studs and layout will be determined by the program based on 100% shear interaction.
  2. Automatic, % interaction - the number of studs and layout will be determined by the program based on the user specified percentage of shear interaction
  3. Automatic, minimum number of shear studs - the number of studs and layout will be determined by the program based on the minimum number of shear studs that also meet the load capacity and minimum shear interaction requirements
  4. User defined - If this is selected, the shear stud definition table will be available and the shear stud number and layout must be defined. If requiring the program to check whether the user defined stud layout meets the code specified spacing requirements, "Check stud spacing" box should be checked. Otherwise, the user defined shear stud number and layout will be used in the analysis regardless of the code requirements
- If there are regions on any side of the beam that do not have shear studs (this is normally required when applying damping layer in this region in floor response analysis), this can be achieved by defining "No stud zone length". No stud zone length can be defined as an absolute length or as a percentage of the beam span.
- Stud steel grade is either user defined or code defined. This option is only available for EN 1994-1-1:2004 design.
- Reinforcement position - position of the reinforcement with reference to underside of the stud. This option is only available for EN 1994-1-1:2004 design.
- Sometimes, EN 1994-1-1:2004 is more restrictive than BS5950 Part 3.1 regarding the minimum

percentage of shear interaction. If EN 1994-1-1:2004 requirements are to be satisfied, check "Use EN 1994-1-1:2004 limit ..." box. If it is checked, the stricter requirements of BS5950 and EN 1994-1-1:2004 will be used. This option is only available for BS5950 design.

- Welded through the profiled steel sheeting - Studs welded through the profiled steel sheeting. This option is only available for EN 1994-1-1:2004 design.
- Use NCCI limits on minimum percentage of interaction - If this is option is selected [NCCI PN-002a](#) minimum interaction rules will be applied. If the condition framed in this document not satisfied EN 1994-1-1:2004 minimum partial interaction rules will be applied. This option is only available for EN 1994-1-1:2004 design.

**Shear Stud**

Standard 19mm/100mm

Non-Standard

Diameter 1.9 cm

Height 10 cm

**No stud zone length**

Left end -0 m or %

Right end -0 m or %

**Stud Steel Grade**

Standard SD1 (EN13918)

Fu 450 [N/mm<sup>2</sup>]

**Reinforcement Position**

Dist below underside of stud head 0.4 [cm]

**Shear Stud Spacing**

Automatic, 100% interaction

Automatic, 85 % interaction

Automatic, Minimum number of studs

User specified  Check stud spacing

	Zone left end (Distance from left)	Group size		Group spacing
		[m], [%]	Number of rows	
Defaults	0	2	1	30
1	0	2	1	30
2	30%	1	1	30
3	70%	2	1	30

Welded through profiled steel sheeting

Use NCCI limits on minimum percentage of interaction if applicable

## 2.4.11 Web Openings

Member Property: Web Openings

- There are 4 types of web openings:
  1. Rectangular
  2. Circular
  3. Left Notch and
  4. Right Notch
- The location of the web opening is defined by the distances of the centre of the web opening to the left end of the beam and the top of the steel beam. These can be specified absolutely or relatively. If specified relatively, the distance to the left is the percentage of the beam span and the distance to the top is the percentage of the steel beam total depth.
- Stiffeners can be defined which can be on both sides or just on one side

- More than one web opening can be defined along the beam. Warnings will be given if the web openings are too close.

	Type	Opening size		Centroid location		Horizontal web stiffeners for the web				
		Width/ Diameter	Height	From left of beam	From top of beam	With stiffener?	Side	Distance from open	Top stiffener	
		[m]	[m]	[m], [%]	[m], [%]				[m]	Width [m]
Defaults	Rectangular	0.4	0.3	50%	50%	No	Both sides	0.05	0.1	0.0
1	Rectangular	0.3	0.1	5	0.3	Yes	Both sides	0.05	0.2	0.0
2	Circular	0.2		7.1	0.3	No				
3	Right notch	0.3	0.1			No				
4										

## 2.4.12 Loads

### Member Property: Loads

- The following load types can be defined:
  1. Linear UDL - uniformly distributed line load.
  2. Point - concentrated point load.
  3. Linear Load - linearly distributed load along the full length of the beam.
  4. Equal Triangle - triangle load starting from left end of the beam and ending at the right; the peak load point is at the mid-span.
  5. General Triangle - triangle load as above, the peak load point can be defined at any position along the beam.
  6. Tri-Linear - tri-linearly distributed loads starting from left end of the beam and ending at the right. The two peak load points can be defined at any positions along the span.
  7. Patch - a distributed load; the positions and load values of the start and end points can be defined at any point along the beam.
  8. Area UDL - uniformly distributed area load. The area subjected to this load is the available width along the full length of the concrete.
  9. Member load - load from other members. It is treated as concentrated load
- Unit - it is dependent on the type of loads and it follows the preferred unit set at "Units" page of the preference wizard
- "Cons dead" and "Cons live" are the construction stage dead and live loads respectively which are used for construction stage analysis.
- "Final dead" and "Final live" are the final (composite) stage dead and live loads respectively which are used for final stage analysis

See "[Treatment of applied loads](#)" for defining construction and final dead loads

	Load Type]	Unit	Load W1				Dist [m], [%]	Load W2			
			Cons dead	Cons live	Final dead	Final live		Cons dead	Cons live	Final dead	Final live
Defaults	Area UDL	N/m <sup>2</sup>	1e+003	1.5e+003	3e+003	5e+003	0	3e+003	4.5e+003	6e+003	5e+003
1	Linear UDL	N/m	1e+003	0	8e+003	0					
2	Point	N	4.59e+00	2.03e+00	6.08e+00	6.75e+00	3				
3	Point	N	5.78e+00	2.55e+00	7.65e+00	8.5e+004	6				
4											

### 2.4.13 Floor Responses

Member Property: Floor Responses

- The data on this page are only used in foot-fall induced floor response analysis
- If this analysis is not required, uncheck "Do foot-fall induced floor response analysis" box to save computing time
- The total transverse direction length of the floor as well as the total number of composite beams need to be defined, the beam centre distance (interval) will be calculated by the program
- Body mass - the maximum body mass of the potential person who will walk on the floor
- Maximum walking frequency - the maximum possible walking frequency to be considered in the analysis. The minimum walking frequency of 1.0 is fixed by the program.
- If damping treatment is applied, check "Apply damping treatment" box and input relevant data
- The schematic floor layout is drawn on the bottom of this page and the red lines represent the composite beams.

Compos7.4\_file.cob: A01:MANUAL

Member Title	Design Options	Design Criteria	Safety Factors	Steel Beam	Restraints in Construction Stage
Concrete Slab	Reinforcement	Decking	Shear Studs	Web Openings	Loads
					Floor response

Do foot-fall induced floor response analysis

**Floor dimension**

Total transverse direction length:  m

Total number of composite beams:

Beam centre distance:  m

**Foot-fall data**

Body mass:  kg

Maximum walking frequency:  Hz

Minimum walking frequency is fixed to 1.0 Hz.

Inherent critical damping ratio (without damping treatment):  %

**Damping treatment**

Apply damping treatment

No stud zone length to apply damping treatment

On left end of the beam:  m or %

On right end of the beam:  m or %

Damping material Young's modulus:  Pa

Damping material shear modulus:  Pa

Damping material lost factor:

Damping layer thickness:  m

Damping layer width:  m

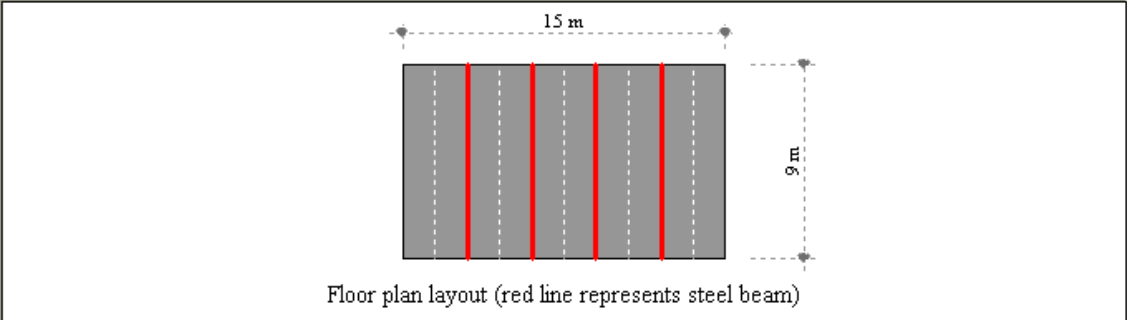

Floor plan layout (red line represents steel beam)

## 2.5 Graphic views

A number of graphic views are available for viewing different aspects of the composite beam. These views can also be used to visually check the input data for any potential errors. There is one 3D graphic view and a number of 2D views.

[3D graphic view](#)

[2D graphic views](#)

### 2.5.1 3D graphic view

3D graphic view shows the image of the composite beam in 3D space. The composite beam can be rotated, enlarged or reduced. Each of the components of the composite beam can be switch on and off individually on the graphic view to enable each of component to be examined individually. Loadings can also be shown schematically on this view. Area loads can be viewed as either converted line load or as area load depending on the preference setting on the page "[3D graphic operations](#)" in the preference wizard.

## 2.5.2 2D graphic views

There are 4 2D graphic views to show different aspects of the composite beam and they are:

**Elevation** - Elevation view of the composite beam. Main dimensions are marked on this view.

**Cross section** - The cross section view of the composite beam. The viewed section can be selected from the section number dropdown combobox. Detailed dimensions are also marked on this view.

**Web opening** - Detailed view of all the web openings in the composite beam. Detailed dimensions are also marked on this view.

**Loading diagram** - Loading diagram of the composite beam. There are 4 diagrams: Construction dead load, Construction live load, Final dead load and final live load. The load diagrams include all the loads for the relevant stage.

## 2.6 Analysis and Design

Before any analysis or design is carried out, Compos checks the input data for errors, inconsistency or non-compliance with the design code. If there are any data errors, the analysis and design will not proceed. Data checking can also be done independently through menu item "Analysis | Check data" or click the relevant Toolbar button.

The following section explains the use of analysis and design in Compos

[Analysis](#)

[Design](#)

### 2.6.1 Analysis

Analysis can be activated through menu item "Analysis | Analyse member(s)" or "Analysis | Analyse group(s)" or by clicking the relevant Toolbar buttons. After this, Analysis/Design Options dialog box will appear. If "Analyse member(s)" has been selected, the selected members will be analysed. If "Analyse group(s)" has been selected, the members within the selected groups will be analysed.

Click OK button to start the analysis, the report view will be opened automatically after analysis starts to present data checking messages and analysis progress.

Note that the Analysis/Design, Member/Group options can also be changed from the Analysis/Design options dialog box.

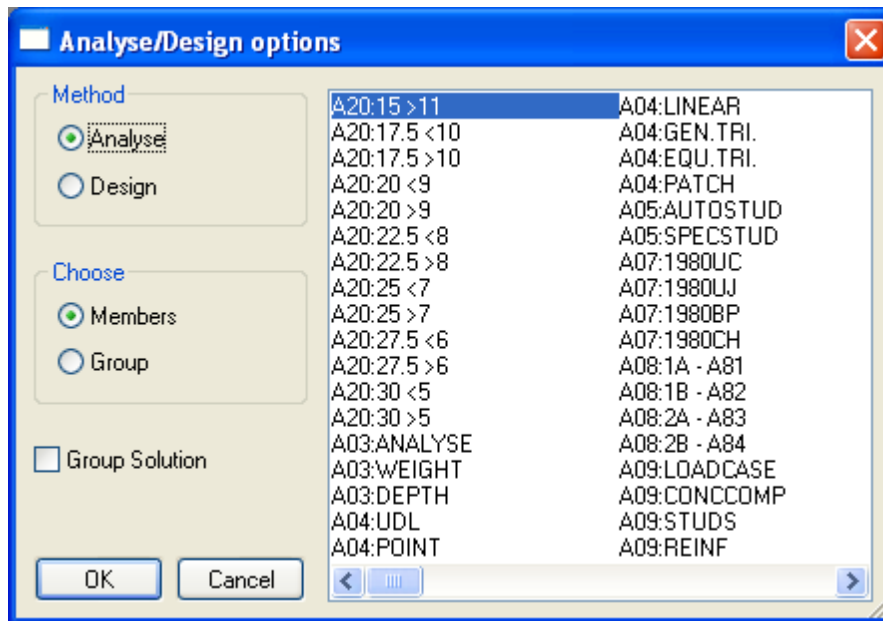

Both construction stage and final stage analysis will be carried out by Compos. In construction stage analysis, only steel beam is considered. If top flange of steel beam is not restrained at construction stage, lateral torsional buckling capacity will be checked. The restraints defined in "Restraints in Construction stage" page of the member property wizard are used to determine the effective length for lateral torsional buckling. The loads at construction stage are considered as destabilising loads if applicable in lateral torsional buckling analysis.

## 2.6.2 Design

Design can be activated through menu item "Analysis | Design member(s)" or "Analysis | Design group(s)" or by clicking the relevant Toolbar buttons. After this, Analysis/Design Options dialog box will appear. If "Design member(s)" has been selected, the selected members will be designed. If "Design group(s)" has been selected, the members within the selected groups will be designed.

Click OK button to start the design, the report view will be opened automatically after design starts to present data checking messages and design progress.

In design, Compos will change the steel beam section (if it is a catalogue section) to meet the minimum weight or minimum depth criteria that are set in the [design criteria](#) page of Member Property wizard and the code requirements

Note that the Analysis/Design, Member/Group options can also be changed from the Analysis/Design options dialog box.

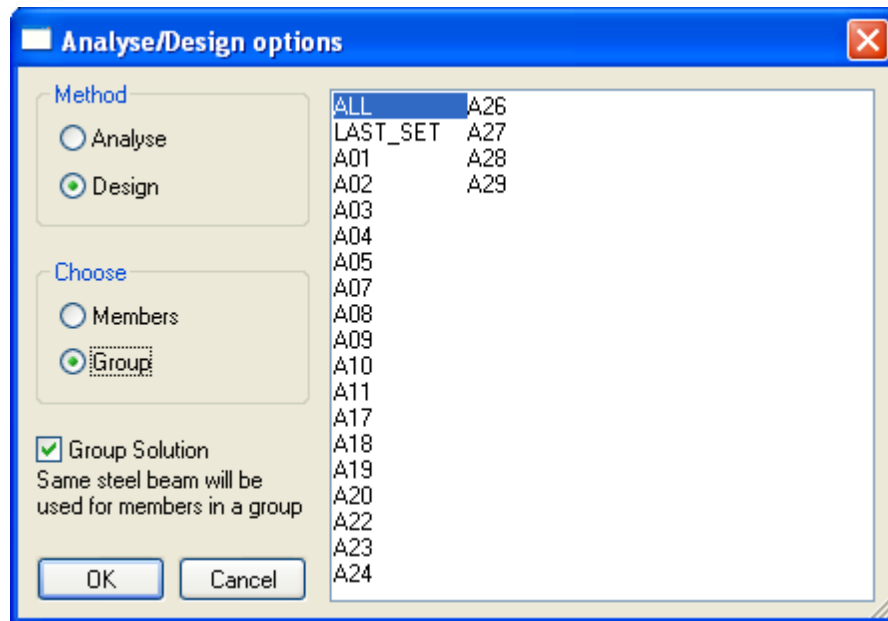

If a group solution is needed, it can be achieved by checking the "Group Solution" box. The group solution option ensures that the steel beams are the same for all the members in the same group.

## 2.7 Results and Output

After a successful analysis or design, results will be available. They can be viewed in text or graphic formats. There are a number of views on both formats to present different aspects of the results

[Text output](#)

[Graphic output](#)

### 2.7.1 Text output

The followings options are available:

- **Overview** - general view of all members in the current group. It shows the utilisation factors of the member as well as some other global analysis results such as natural frequency.
- **Summary (text only)** - input data and results summary in text only format. Before opening the summary result view, a dialog box is presented to filter the output.
- **Summary (with graphic)** - as Summary (text only), but with embedded graphic views.
- **Detailed result** - A tabular view to give detailed analysis results for each of the critical sections along the member, e.g, the moment, shear force, moment capacity and shear capacity etc.

Notes:

1. Addi. dead - Additional dead load which is equal to final dead load minus construction dead load.
2. X - Neutral axis position measured from the bottom of steel beam
3. Weld thickness - the throat thickness of welding, this thickness is calculated based on the equal shear strength of the welding and the steel beam web.
4. Construction dead load deflection - Deflection generated by construction dead loads which

- are supported by steel beam only
  5. Additional dead load deflection - deflection generated by additional dead load which are supported by the composite beam
  6. Final live load deflection - deflection generated by final live load which are supported by the composite beam
  7. Final total deflection - the sum of Construction dead load deflection, additional dead load deflection and final live load deflection
  8. Post-construction deflection - it equals Final total deflection minus Construction dead load deflection
  9. Mode shape - the first mode shape of the beam which is used in calculating the beam frequency
- **Calculation procedures** - A text output to show the calculation procedures similar to hand calculations. It is useful for checking why a member has failed etc. The calculation procedures are only available for construction stage analysis.
  - **Stud layout** - A tabular output to show stud layout. If the stud layout is user defined, this will be the same as that defined at "[Shear studs](#)" page of member property wizard.
  - **Transverse reinforcement** - A tabular output to give the layout of transverse reinforcement. A summary of transverse shear and resistance for the critical section is also presented in this output.
  - **Web opening** - A tabular output to summarise the analysis of web openings.

## 2.7.2 Graphic output

The followings are the graphic output of analysis results

- **Moment diagram** - Moment diagrams and moment capacity diagrams
- **Shear force diagram** - Shear force diagrams and shear capacity diagrams
- **Partial interaction** - Diagram of moment - shear interaction relationship
- **Moment/shear interaction** - Diagram of moment capacity - shear force relationship
- **Deflections** - Diagram of deflections for the various loading stages
- **Centre point response** - Diagram of foot-fall induced floor response versus the walking frequencies for the center point of the floor. Floor frequencies up to 15 Hz., Critical damping ratio (including damping treatment) as well as modal mass are also given on this diagram.
- **Centre line response** - Diagram of maximum floor response along the center line of the floor (half has been plotted and the center line is in the direction crossing the composite beam). Floor frequencies up to 15 Hz., Critical damping ratio (including damping treatment) and modal mass are also given on this diagram.

## 2.8 Tools

There are three tools to help managing the groups and members in the "Data Manager", they are

[Remove empty groups](#)

[Sort in ascending order](#)

[Sort in descending order](#)

### 2.8.1 Remove empty groups

**Remove empty groups** - Remove all the groups that do not contain any members.

### 2.8.2 Sort in ascending order

**Sort in ascending order** - Sort groups and members in alphabetic ascending order.

### 2.8.3 Sort in descending order

**Sort in descending order** - Sort groups and members in alphabetic descending order.

## 2.9 Compos Text (ASCII) File

The format of the text data file is a record by record file with fields separated by tabs or commas.

The file consists of a series of records, each record consisting of a key word and a number of fields each separated with a tab or comma. There may only be one record per line, but a record may be continued on more than one line. To spread a record over several lines a continuation marker (a \) should be placed in the next field position on that line. Comments can be included in the file on any line after a comment marker (an !) character. The \ should precede any comments and anything after the continuation marker will be treated as a comment. Both comments and continuation characters should be separated from the fields by a tab or comma. Blank lines (no space or tab characters) are acceptable. A blank field is interpreted as a null string for string fields and a zero for numeric fields.

Each record is of the form:

KEY\_WORD, value, value, value, value

for example

```
WEB_OPEN_DIMENSION      Member_1      RECTANGULAR      0.4      0.3      40.0%  
50.0% STIFFENER_NO
```

where:

WEB\_OPEN\_DIMENSION - key word for web opening dimension

Member\_1 - the member name

RECTANGULAR - the web opening is rectangular

0.4 - the width of the opening

0.3 - the height of the opening

40.0% - the horizontal position of the opening to the left end of the beam is 40% of the span length

50.0% - the vertical position of the opening to the top of steel beam is 50% of the overall depth of the steel beam

STIFFENER\_NO - flag indicates there is no web opening stiffeners

### Units

Compos data is stored in SI units both in COB files and in the program. In text files, however, data units are set by UNIT\_DATA records, defaulting to SI. The syntax of the UNIT\_DATA record is described in the Compos Text (ASCII) File format section.

When reading a COA file Compos registers the current unit for each unit type, defaulting to SI. Units may be adjusted several times in one COA file to use different unit for different data.

When writing COA files Compos offers the option to export in SI units or model units. When the option to export in model units is taken a set of UNIT\_DATA records is written at the top of the file, specifying the current model units, and all data are written in those units.

## 2.9.1 Compos Text (ASCII) File: keywords

Details of the keywords are available in the ComposTextFile.html file in the Compos folder.

## 2.10 File I/O

[Compos data file](#)

[Import/Export](#)

### 2.10.1 Compos Data File

Compos supports both binary and text data file. Text data file can be either tab separated (\*.coa) or comma separated (\*.csv) which can be edited from any text editor or spreadsheet. See Compos Text (ASCII) File for all the keywords and format of text data file.

### 2.10.2 Import/Export

**Import Member(s)** - Members in other Compos files can be imported into the currently opened Compos file. If there are duplicated members in the opened file and the imported file, options will be given to keep members in the opened file or in the imported file. Import members can be invoked through menu item "File | Import Member(s)".

**Export Member(s)** - Selected members in the opened Compos file can be exported to a Compos file which can be opened or imported by Compos. Export Member(s) can be invoked through menu item "File | Export | Member(s)".

**Export Overview Results** - Overview results can be exported into a tab or comma separated data file. This can be done through menu item "File | Export | Overview".

**Export Detailed Results** - Detailed results can be exported into a tab or comma separated data file. This can be done through menu item "File | Export | Detailed results".

**Export Output View** - Data and results in an output view can be exported to file in tab separated CSV or HTML formats. It can be done through menu item "File | Export | Output (TSV, CSV or HTML file)".

## 2.11 Programming Interface

Programming interface is provided by [COM Automation](#) in Compos

COM Automation allows commands to be issued from a separate process via a set of VBA or C++ instructions. The separate process could be a separate program or, indeed, a VBA script in a

spreadsheet.

## 2.11.1 COM Automation

COM Automation allows other programs to access to Compos operations by creating an instance of Compos class "Compos.Automation" and calling the exported functions of this class. A log file will be created to record the execution of each of the functions. The available COM export functions are listed below.

Note that function names are case sensitive.

### More:

[COM Export Functions](#)

[COM VBA Example](#)

[COM C++ Example](#)

### 2.11.1.1 COM Export Functions

The Compos COM export functions are listed below:

The use of many of these functions is demonstrated in sample Excel (XLS) files that are installed in the Samples folder in the Compos program folder. In particular, macros in the sample file `ComposCOMSample.xls` exercise most of these Compos COM functions.

#### **short New()**

Open a new model. Returns a status, as follows:

- 0 – OK
- 1 – failed to create the file

#### **short Open (filename)**

Open a COB, COA or CSV file. Returns a status, as follows:

- 0 – OK
- 1 – failed to open

**filename** – the name of the file to be opened, including path and extension.

#### **short Save ()**

Save the data to the default file (i.e. overwriting the file that was opened or last saved). Returns a status, as follows:

- 0 – OK
- 1 – no Compos file is open
- 2 – no default path is available; use SaveAs
- 3 – failed to save

#### **short SaveAs (filename)**

Save the data to COB, COA or CSV file. Returns a status, as follows:

- 0 – OK
- 1 – no Compos file is open
- 2 – invalid file extension
- 3 – failed to save

**filename** – the name of the file to be saved, including path and extension.

#### **short Close ()**

Close the current file. Returns a status, as follows:

- 0 – OK
- 1 – no GSA file is open

#### **short Analyse (membername)**

Analyse the member with the given name. Returns a status, as follows:

- 0 – OK
- 1 – failed

*membername* – the name of the member to be analysed.

#### **short Design (membername)**

Design the member with the given name. Returns a status, as follows:

- 0 – OK
- 1 – failed

*membername* – the name of the member to be designed.

#### **short NumMember ()**

Return the total number of members in the file

#### **short MemberName (index)**

Return the name of member with the given index

*index* – the index of the member in default group "ALL".

#### **string BeamSectDesc (membername)**

Return the description of the first steel beam section

#### **float UtilisationFactor (membername, option)**

Return the utilisation factor (natural frequency) for the given member and the option

**option** – valid options are (string):

- FinalMoment
- FinalShear
- ConstructionMoment
- ConstructionShear
- ConstructionBuckling
- ConstructionDeflection
- FinalDeflection
- TransverseShear
- WebOpening
- NaturalFrequency

#### **short CodeSatisfied (membername)**

Return an integer flag to indicates whether the code requirements are satisfied. The return values are:

- 0 - all code requirements are met
- 1 - except the natural frequency is lower than that required, other code requirements are met
- 2 - one or more code requirements are not met
- 3 - the given member name is not valid

4 - there is no results for the given named member

### 2.11.1.2 COM VBA Example

The following is an example VBA script to run Compos remotely.

```
Sub RunCompos()  
    Dim ComposAuto As Object  
    Set ComposAuto = CreateObject("Compos.Automation")  
    Dim Name1, Name2, Name3, Name4, MemName, Sect As String  
    Dim Num As Integer  
    Dim Factor1, Factor2, Factor3, Factor4, Factor5 As Double  
    Dim Factor6, Factor7, Factor8, Factor9, Frequecy, CodeMet As Double  
  
    Name1 = "c:\Temp\ComposFile1.cob"  
    Name2 = "c:\Temp\ComposFile2.coa"  
    Name3 = "c:\Temp\ComposFile3.csv"  
    Name4 = "c:\Temp\ComposFile4.cob"  
  
    ComposAuto.Open Name1  
    Num = ComposAuto.NumMember  
  
    If Num < 1 Then  
        ComposAuto.Close  
        Set ComposAuto = Nothing  
        Return  
    End If  
  
    MemName = ComposAuto.MemberName(0)  
    ComposAuto.Analyse (MemName)  
    Factor1 = ComposAuto.UtilisationFactor(MemName, "FinalMoment")  
    Factor2 = ComposAuto.UtilisationFactor(MemName, "FinalShear")  
    Factor3 = ComposAuto.UtilisationFactor(MemName, "ConstructionMoment")  
    Factor4 = ComposAuto.UtilisationFactor(MemName, "ConstructionShear")  
    Factor5 = ComposAuto.UtilisationFactor(MemName, "ConstructionBuckling")  
    Factor6 = ComposAuto.UtilisationFactor(MemName, "ConstructionDeflection")  
    Factor7 = ComposAuto.UtilisationFactor(MemName, "FinalDeflection")  
    Factor8 = ComposAuto.UtilisationFactor(MemName, "TransverseShear")  
    Factor9 = ComposAuto.UtilisationFactor(MemName, "WebOpening")  
    Frequecy = ComposAuto.UtilisationFactor(MemName, "NaturalFrequency")  
  
    CodeMet = ComposAuto.CodeSatisfied(MemName)  
  
    ComposAuto.SaveAs Name2  
    ComposAuto.SaveAs Name3  
  
    Sect = ComposAuto.BeamSectDesc(MemName)  
    ComposAuto.Design (MemName)  
    Sect = ComposAuto.BeamSectDesc(MemName)  
  
    ComposAuto.SaveAs Name4  
    ComposAuto.Close  
    Set ComposAuto = Nothing  
End Sub
```

### 2.11.1.3 COM C++ Example

The following is an example C++ code to run Compos remotely.

```
void RunCompos()
{
    COleDispatchDriver cComposDispDriver;
    cComposDispDriver.m_bAutoRelease = true;
    BYTE                pArgType1[] = "";
    BYTE                pArgType2[] = VTS_BSTR;
    CString             csPath1("c:\\temp\\Compos_file1.coa"),
                      csPath2("c:\\temp\\Compos_file2.cob");

    // Create an instance of the Compos class "Compos.Automation"
    if(!cGsaDispDriver.CreateDispatch("Compos.Automation"))
    {
        AfxMessageBox(
            "Compos not found or not registered");
        return;
    }

    bool bStat(true);
    // Function Open
    if(bStat)
        bStat = RunOneFunction(&cComposDispDriver,
                               "Open",
                               pArgType2,
                               csPath1);

    // Function Save
    if(bStat)
        bStat = RunOneFunction(&cComposDispDriver,
                               "Save",
                               pArgType1,
                               "");

    // Function SaveAs
    if(bStat)
        bStat = RunOneFunction(&cComposDispDriver,
                               "SaveAs",
                               pArgType2,
                               csPath2);

    // Function Close
    if(bStat)
        bStat = RunOneFunction(&cComposDispDriver,
                               "Close",
                               pArgType1,
                               "");

    // (ReleaseDispatch need not be called when
    // cComposDispDriver.m_bAutoRelease = true;
    // is set, as above)
    // cComposDispDriver.ReleaseDispatch();
}
```

```

bool RunOneFunction(
    COleDispatchDriver*    pDispDriver,
    CString                csFuncName,
    BYTE*                  pArgType,
    CString                csArgument)
{
    DISPID                dispid;
    OLECHAR*              pcsFunc;
    CString                csMsg;
    int                    iReturn(0);
    pcsFunc = csFuncName.AllocSysString();

    //Find the function ID
    if(pDispDriver->m_lpDispatch->GetIDsOfNames(
        IID_NULL,
        &pcsFunc,
        1,
        NULL,
        &dispid) != S_OK)
    {
        csMsg.Format("Function (%s) cannot be found", csFuncName);
        AfxMessageBox(csMsg);
        return false;
    }

    //Run the function
    if(csArgument.IsEmpty())
        pDispDriver->InvokeHelper(
            dispid,
            DISPATCH_METHOD,
            VT_I2,
            &iReturn,
            pArgType);
    else
        pDispDriver->InvokeHelper(
            dispid,
            DISPATCH_METHOD,
            VT_I2,
            &iReturn,
            pArgType,
            csArgument);

    if(iReturn != 0)
        return false;
    else
        return true;
}

```

# Technical notes

**Part**

---

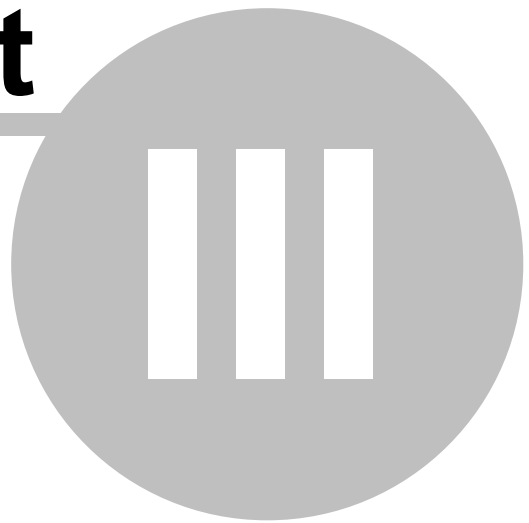

### 3 Technical notes

This chapter describes aspects of the methods Compos uses when performing calculations.

#### 3.1 Critical Sections

Critical sections are those sections for which Compos will check capacities and give detailed results. The critical sections are those sections meeting one of the following criteria.

1. Both ends of the beam
2. Section with point constraints
3. Section dimension changes
4. Section with point or member loads
5. Start and end section of Patch loads
6. Start and end section of web openings
7. Construction and final stage maximum moment sections
8. Sections with composite beam moment capacity larger than 2.5 steel beam moment capacity (Clause 5.4.5.4 of Part 3.1 of BS5950)
9. Section of stud spacing changes
10. Start and end of no-stud zones

The largest distance between critical sections can be set from "[Input Data](#)" page of the Preference wizard. If the distance between critical sections determined above is longer than this, more critical sections will be added until this requirement is met

#### 3.2 Construction dead load

Construction dead loads should include only those loads that are present as the concrete sets. This part of the load is used to calculate the elastic stresses in the steel beam before composite action can occur. Other construction loads should be specified as construction live loads. If steel beam weight or concrete slab weight are included (specified on "[Design Options](#)" page of Member Property wizard), they will be treated as construction dead loads.

#### 3.3 Longitudinal shear force

The total longitudinal shear force per unit length ( $V$ ) used to check slab splitting capacity and design transverse reinforcement is taken as:

if the actual percentage of shear interaction ( $p_a$ ) is smaller than 150%

$$V = \frac{NQ}{s}$$

otherwise

$$V = \frac{NQ}{s} \frac{1.5}{p_a}$$

where:

N - the number of shear connector in a group  
 Q - one shear connector shear resistance  
 s - longitudinal spacing of groups of shear connectors  
 p<sub>a</sub> - actual shear interaction

Note:

Because the longitudinal shear force is based on a plastic distribution, actual shear force attracted by the connectors will increase with the number of shear connectors even if full interaction is provided. The 1.5 factor is a reasonable upper bound as this value.

### 3.4 Minimum percentage of shear interaction

Minimum percentage of shear interaction (p<sub>b</sub>) given by BS5950 Part 3.1 (reference 2) is:

If L < 10 m, p<sub>b</sub> = 40%  
 if L > 16 m, p<sub>b</sub> = 100%  
 otherwise p<sub>b</sub> = (L - 6)/10

Minimum percentage of shear interaction (p<sub>e4</sub>) given by Eurocode 4 (reference 4) is:

if the top and bottom flange are equal  
 if(L < 5 m) p<sub>e</sub> = 40%  
 if(L > 25 m) p<sub>e</sub> = 100%  
 otherwise p<sub>e</sub> = 0.25 + 0.03xL

if the bottom flange is bigger than the top  
 if(L > 20 m) p<sub>u</sub> = 100%  
 otherwise p<sub>u</sub> = 0.4 + 0.03xL

If Ar is the area ratio between bottom flange and top flange (if Ar < 1.0, Ar = 1.0; if Ar > 3.0, Ar = 3.0), the minimum percentage of shear interaction given by Eurocode 4 is:

$$p_{e4} = (p_e + p_u)/2 \times (Ar - 1) + p_e.$$

If Eurocode 4 rule is not applied (see page "[Shear studs](#)" of member property wizard), p<sub>b</sub> will be used for the minimum percentage of shear interaction, otherwise the largest value of p<sub>b</sub> and p<sub>e4</sub> will be used as the minimum percentage of shear interaction.

### 3.5 Moment capacity of slender composite section

If the steel beam section is classified as slender in a composite section, the moment capacity is calculated as following in Compos.

The elastic moment resistance of composite section with full shear interaction is given by the minimum of three following values:

$$M_{e,comp,c} = 0.5f_{cu}W_{e,comp,c} + M_{dconst}$$

$$M_{e,comp,tf} = \left( p_y - \frac{M_{dconst}}{W_{e,tf}} \right) W_{e,comp,tf} + M_{dconst}$$

$$M_{e,comp,bf} = \left( p_y - \frac{M_{dconst}}{W_{e,bf}} \right) W_{e,comp,bf} + M_{dconst}$$

i.e.

$$M_{e,comp} = \text{Min}(M_{e,comp,c}, M_{e,comp,tf}, M_{e,comp,bf})$$

where:

$M_{dconst}$  The locked in stress from the factored permanent construction loads in unpropped construction

$N_c$  The force in the slab limited by the shear connectors, the concrete resistance or the steel resistance

$W_{e,comp,c}$  Section modulus for the composite section based on the effective modular ratio and for the stress in the top of the concrete slab

$W_{e,comp,tf}$  Section modulus for the composite section based on the effective modular ratio and for the top flange of the steel section

$W_{e,comp,bf}$  Section modulus for the composite section based on the effective modular ratio and for the bottom flange of the steel section

$W_{e,tf}$  Section modulus for the top of the steel section

$W_{e,bf}$  Section modulus for the bottom of the steel section

$p_y$  Yield strength of steel

$f_{cu}$  Concrete cube strength

The section moduli mentioned above are to be calculated using an effective flange area of the compression flange if it is slender (class 4). Initially the gross area of the web is to be used.

If the axial force available ( $N_c$ ) is less than that necessary to mobilise  $M_{e,comp}$  then the resistance moment must be calculated allowing for some slip between the slab and the steel beam. This is carried out by assuming that both the steel beam and concrete slab have the same curvature. Here the resistance moment is governed by yielding of the steel and it is calculated as follows.

The moment in the steel section post construction is given by the following expression:

$$M_{post} = \text{Min} \left( \left( p_y - \frac{N_c}{A} \right) W_{e,bf}, \left( p_y + \frac{N_c}{A} \right) W_{e,tf} \right) - M_{dconst}$$

The curvature due to loads after construction is then given by:

$$K = M_{post} / (EI)$$

Not all the concrete may be in compression. If it is not, the axial force will be given by:

$$N_c = 0.5KEb_{ceff}d_c^2 \text{ and therefore}$$

$$d_c = \text{Min}((d_s - d_p), \sqrt{2N_c / (KEb_{ceff})})$$

The second moment of inertia of the effective concrete section is:

$$I_{ceff} = b_{ceff}d_c^3 / 12$$

The total resistance moment is then given by the expression:

$$M_{slip} = M_{post} \left( 1 + \frac{I_{ceff}}{I} \right) + N_c (D + d_s - X - 0.5d_c) + M_{dconst}$$

Where:

A	Area of steel beam
A <sub>ceff</sub>	Area of concrete divided by effective modular ratio
b <sub>ceff</sub>	Effective width of concrete slab divided by effective modular ratio
I	Second moment of area of steel section
D	Depth of steel section
X	Position of neutral axis of steel section above the bottom flange
d <sub>s</sub>	Depth of slab
d <sub>p</sub>	Depth of profile
E	Young's modulus for steel
I	Second moment of area of the steel
K	Curvature
d <sub>c</sub>	Depth of concrete in compression

### 3.6 Optimal Beam Design

When doing design, Compos will design the most efficient steel section available in the selected section types (see "[Design criteria](#)" page of Member Property wizard) in the section database. The section selection is based on either minimum weight or minimum depth criteria defined on "[Design criteria](#)" page of the Member Property wizard.

## 3.7 Shear Stud Design

Compos can automatically design stud layout if it is not defined as user specified on "[Shear studs](#)" page of the Member Property wizard.

### Number of Stud Zones

Compos can automatically calculate the required spacing of studs using up to the maximum number of stud zones set on "[Input data](#)" page of the Preferences wizard. The maximum number of stud zone is limited to 3 by the program.

### Saving of shear studs

Usually, using two or three stud zones will require less number of shear studs, however, from practice point of view, more stud zones will increase the complexity of stud welding. For this reason, the program allows the user to specify a minimum percentage of savings of the shear studs when using 2 or 3 shear stud zones. If the saving of the shear studs is less than that percentage specified, one stud zone will be used even though it is not the most economical design in terms of the number of shear studs.

If one stud zone will be required for all the composite beams, this can be achieved by setting the "maximum allowable number of stud zones" to 1 on "[Input data](#)" page of the preference wizard.

## 3.8 Serviceability Limit State

### Load factors

Calculations are performed with **unfactored** loads.

### Effective Modular Ratio

Effective modular ratio is calculated by interpolating between short-term and long-term modular ratios and accounting for percentage of live load acting long term (see "[Concrete slab](#)" page of the Member Property wizard).

The effective modulus ratio is used to calculate the effective second moment of area of the composite section which is used in the composite section moment capacity calculation of semi-compact and slender composite sections. It is also used in the classification of steel beam web of the composite section if the flange is semi-compact or slender.

The effective modular ratio is **not** used when calculating deflections and stresses. Instead, separate long and short term values are used for long and short term loading to give more accurate results.

### Deflections

The increased deflection under partial interaction is calculated using Clause 6.1.4 and applying the percentage interaction at the critical point to the whole beam.

### Maximum Stresses

At SLS the stress in the steel beam is limited to  $p_y$  and in the concrete to  $0.5 \times f_{cu}$ . The effects of dead load applied at construction and composite stages are taken into account separately.

### Composite Beam Natural Frequency Analysis

The lowest natural frequency of a Composite beam is calculated, where the steel/concrete material modular ratio for vibration is used. The default ratio is taken from Steel Construction Institute publication SCI 076.

Due to the nature of the loading, it is assumed that the shear interaction is 100% between concrete slab and steel beam when calculating the natural frequency. Partial shear interaction does not therefore affect the natural frequency. However, if no-stud zones are defined, the sum of Steel beam EI and concrete slab EI is used as the overall EI of the whole section when calculating the natural frequency.

### Foot-fall induced floor responses

If it is enabled on "[Floor responses](#)" page of Member Property wizard, the floor frequency and floor responses factor will be calculated and the results can be viewed graphically. In order to reduce floor response, damping treatment can be applied to both ends of the composite beam within the no-stud zones. The data input for damping treatment is on "[Floor responses](#)" page of the Member Property wizard.

## 3.9 Tapered steel beam

### Tapered steel beam

#### 1. Effective thickness of the tapered flange

The effective thickness of tapered flange is taken as  $t_{fb} \times \cos(a)$  and the cross section properties are calculated using the effective thickness  $t_{fb} \times \cos(a)$ .

#### 2. Effective shear force of the tapered section

The elastic stress at the centre of the tapered flange is calculated. If the calculated value is greater than the design strength of the material it is taken as equal to the design strength. The force in the tapered flange ( $F_b$ ) is calculated (tension positive), the effective shear force on the section is reduced by  $F_b \times \tan(a)$  if shear  $V$  is positive as shown below, otherwise, the effective shear force should be increased by  $F_b \times \tan(a)$ .

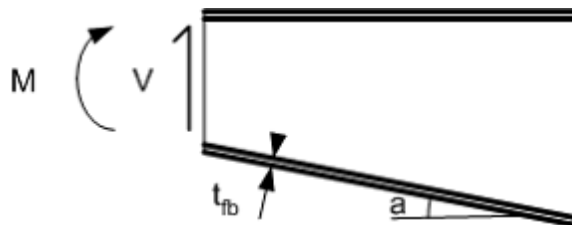

**Tapered beam**

#### 3. Check at the change of flange direction (see Fig below)

- (a) Web local capacity check,  $2W \leq 7 t_{fb} t_w p_y$  (see Clause 3.2.4 of reference 7)
- (b) Web buckling capacity check (see Clause 3.2.4 reference 7)
- (c) Flange bending capacity check (see Clause 3.2.4 reference 7)

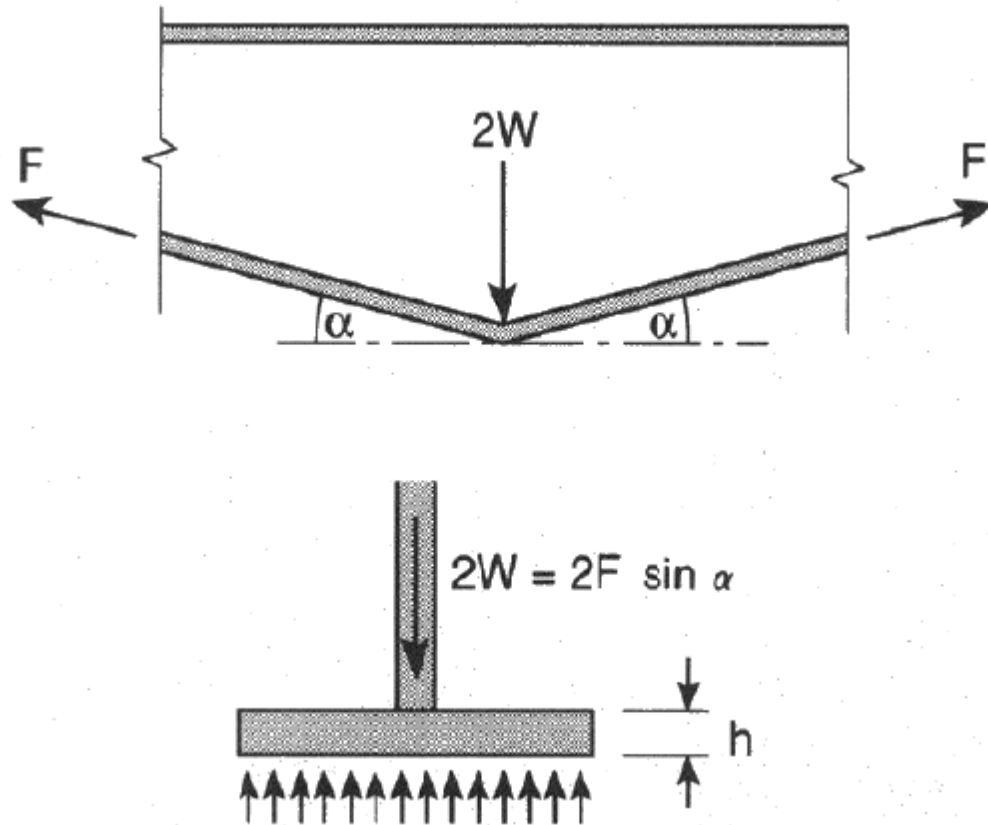

Change of flange direction of tapered beam

### 3.10 Ultimate Limit State

#### Load factors

Calculations are performed with **factored** loads and **factored** material strengths. Compos performs a plastic analysis, except for beams with a slender web or semi-compact/slender flange, for which Compos performs an elastic analysis according to the design codes.

Note that the classification of a beam may vary along its span as the beam neutral axis depth and/or concrete-beam shear interaction changes.

#### Plastic Moment Capacity

A general formula is used that allows for beams with unequal flanges and plastic neutral axis anywhere in the beam or concrete.

#### Elastic Moment Capacity

The design stress in the steel beam is limited to  $p_y$  and in the concrete to  $0.5 \times f_{cu}$ . The separate effect of dead load applied at construction and composite stages is taken into account.

### 3.11 Web opening analysis

Steel Construction Institute (SCI) publication 068 - "Design for openings in the webs of composite beams" is now superseded by SCI P 355 - "Design of composite beams with large web openings". From version 8.3 onwards web opening analysis in Compos is in accordance with SCI P 355. See [SCI P 068 Implementation](#) and [SCI P 355 Implementation](#) for details. SCI P 355 is based on the principles of EN 1993-1-1 and EN 1994-1-1. For BS5950 design codes web analysis is in accordance with SCI P 355 but the flange classification and the checks for shear and buckling is in accordance with BS5950 design codes.

### 3.12 Web opening effect on deflection

Deflection is calculated in Compos using numerical integration as shown below

$$f_x = \sum \int_{x_i}^{x_{i+1}} \frac{M_p M_1}{EI} dx + \sum \int_{x_i}^{x_{i+1}} \frac{V_p V_1}{GA} dx$$

where:

$f_x$  is the deflection at section  $x$  ( $x$  is the distance of the section to the left end of the beam)

$x_i$  and  $x_{i+1}$  is the start and end sections of the integration, they are the sections with sudden change of beam, slab or loads

$M_p$  is the moment generated by imposed loads

$M_1$  is the moment generated by unit load at location  $x$

$V_p$  is the shear force generated by imposed loads

$V_1$  is the shear force generated by unit load at location  $x$

$E$  is steel material Young's modulus

$I$  is the second moment of area of the section

$G$  is the shear modulus of steel material

$A$  is the effective shear area

When integrating over the web openings, the  $EI$  and  $GA$  are calculated considering the web opening.

#### I value at web opening

$I$  is calculated using net section area, i.e. the web opening is excluded.

#### GA at web opening

$GA$  is calculated from:

$$GA = \frac{1}{\frac{l^3}{12EI_t} + \frac{l}{GA_t}} + \frac{1}{\frac{l^3}{12EI_b} + \frac{l}{GA_b}}$$

where:

$l$  is the width of the web opening

$I_t$  is the second moment of area of top T section of the web opening

$A_t$  is the web area of top T section of the web opening

$I_b$  is the second moment of area of bottom T section of the web opening

$A_b$  is the web area of bottom T section of the web opening

### 3.13 Welding Design

#### Welds between steel beam web and flange of welded steel section (see also reference 7)

The unit length shear force ( $V$ ) between steel beam web and flange is calculated as followings

for weld between top flange and web, the unit length shear force ( $V$ ) is taken as the largest value of the followings

- the difference of shear resistance of shear connectors between previous critical section and next critical section
- the difference of top flange forces between previous critical section and next critical section at construction stage (factored construction stage loads)
- the difference of top flange forces plus concrete slab force between previous critical section and next critical section at final stage (factored final stage loads)

for weld between bottom flange and web, the unit length shear force ( $V$ ) is taken as the largest value of the followings

- the difference of bottom flange forces between previous critical section and next critical section at construction stage (factored construction stage loads)
- the difference of bottom flange forces between previous critical section and next critical section at final stage (factored final stage loads)

After obtaining the unit length shear force for welds, the throat thickness of welds is calculated from:

$$a = \frac{V}{2p_w}$$

where:

$a$  - the throat thickness of the welds which are both sides of the web

$V$  - unit length shear force for weld to resist

$p_w$  - the design strength of welding material

### 3.14 Width and depth of concrete slab

As variable width/depth of concrete slab can be defined in Compos, a rule is needed to determine the available width/depth of the slab along the beam. In Compos, a 45 degree rule is used to determine the available width and depth of the slab as shown in the following diagram. In this way, the available/effective width of the concrete slab at the end of the composite beam will be zero, so

the composite properties will be the same as the steel beam

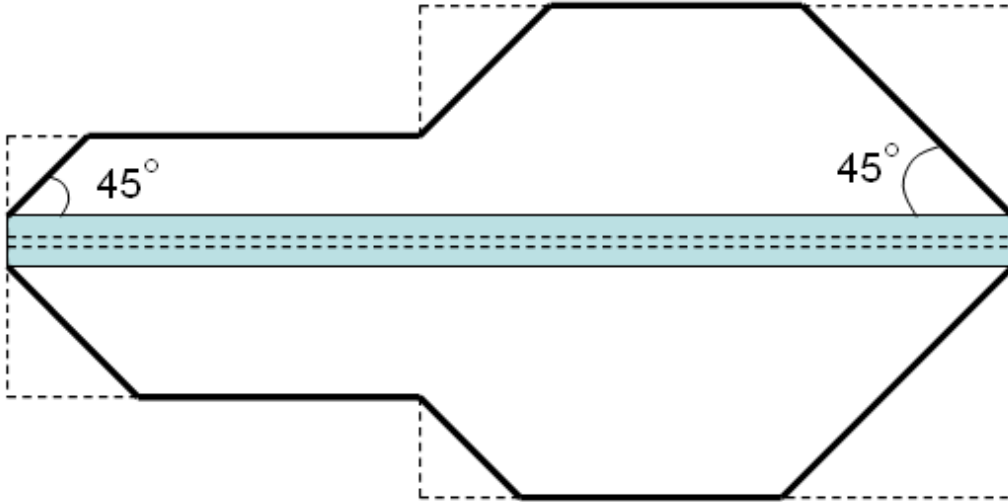

Plan view of composite beam  
(the dashed line shows the actual width of the slab and the solid line shows the available width of the slab used by Compos)

# Appendices

## Part

---



IV

## 4 Appendices

[BS5950 Interpretation by Compos](#)  
[SCI P 068 Implementation](#)  
[References](#)

### 4.1 BS5950 Interpretation by Compos

All clause references are to BS 5950 Part. 3.1 : 1990 unless otherwise stated.

**More:**

[Section 1. General](#)  
[Section 2. Limit state design](#)  
[Section 3. Materials](#)  
[Section 4. Section properties](#)  
[Section 5. Composite beams: Ultimate limit state](#)  
[Section 6. Composite beams: Serviceability](#)  
[Appendix A. Guidance on additional aspects of construction.](#)  
[Appendix B. Plastic moment capacity](#)  
[Appendix C. Classification of webs](#)  
[Appendix D. Plastic analysis, general method](#)

#### 4.1.1 Section 1. General

The overall design procedure is in accordance with BS 5950:Part 1, except when modified and supplemented by the recommendations of Part 3.1.

#### 4.1.2 Section 2. Limit state design

[2.1 General Principles](#)  
[2.2 Loading](#)  
[2.3 Ultimate Limit States](#)  
[2.4 Serviceability Limit States](#)

##### 4.1.2.1 2.1 General Principles

###### 2.1.2 Method of design

The simple method of design is used and beams are assumed to be simply supported.

###### 2.1.3 Method of analysis

Plastic/elastic moment capacity is used depending on classification of flange and web. Slender beams and beams with varying classification along the span are permitted.

##### 4.1.2.2 2.2 Loading

Frequency of fluctuating loads is not considered.

The user must enter the construction loads.

The modular ratio in [Clause 4.1](#) is calculated automatically but the user can specify a different value. Creep is not considered separately if the value of modular ratio is specified by the user.

Temperature effects are not considered.

### 2.2.2 Dead, imposed and wind loads.

The user must supply all loads, although the steel beam and concrete slab selfweight can be included automatically. The loading (bending moment) along the beam must always be higher in the final stage than at construction stage.

### 2.2.3 Construction loads and temporary storage loads.

The self-weight of beam and concrete slab is not automatically included. If they should be included, the relevant check box should be checked on "[Design options](#)" page of property wizard. No check is made to ensure that the construction load is not less than 0.5 kN/m<sup>2</sup>. The alternative construction point load of 4kN is not considered unless the load is entered in the load table.

## 4.1.2.3 2.3 Ultimate Limit States

### 2.3.1 General

Moment capacity are checked at all the [critical sections](#) along the beam.

The compression flange is always assumed to be laterally restrained in composite stage. The following checks are made at the ultimate limit state (factored loads):

- Construction stage moment capacity
- Composite stage moment capacity
- Construction stage shear capacity
- Composite stage shear capacity

If an elastic analysis is performed, stress in beam ( $f_s$ ) is limited to  $f_s < p_y / \gamma_m$ , where  $\gamma_m$  is the material safety factor for the beam (1.0 in BS5950), and  $p_y$  is steel yield strength.

In an elastic analysis, concrete stress is limited to  $0.5 \times f_{cu}$  in outermost fibre.

In elastic analysis, locked-in dead load stresses at construction stage are considered separately from loads applied in the composite stage. This means that only the additional dead loads in the composite stage are applied to the composite beam.

In plastic analysis of a composite beam at intermediate sections, the stress block method is used to calculate the moment capacity. In an elastic analysis, the elastic force in concrete slab is limited to the total shear capacity of the all the shear studs from the section in question to the support section.

Default value of  $\gamma_m$  is 1.6 for live loads and 1.4 for dead loads.

### 2.3.2 Construction stage

At the construction stage the concrete does not contribute to the strength. Constraints to the steel beam at construction stage can be defined on "[Restraints in construction](#)" page of the property wizard.

## 4.1.2.4 2.4 Serviceability Limit States

Beam and concrete stresses are checked at all the critical sections.

As allowed in [6.2](#) no account is taken of partial shear connection in the calculation of elastic section moduli and 100% interaction is used.

The following checks are made at the serviceability limit state (unfactored loads):

1. Dead load deflection at construction stage.
2. Additional dead load deflection at composite stage.
3. Final live load deflection at composite stage.
4. Final Total load deflection at composite stage.

5. Working construction loads,  $f_s \leq p_y$  beam only.
6. Working final loads,  $f_s \leq p_y$ ,  $f_c \leq 0.5 \times f_{cu}$ , composite.

If the construction is propped at the construction stage, 1) and 5) are not checked.

In 6) only additional dead load stresses at composite stage are applied to the composite beam.

Cracking and durability is not considered.

In vibration analysis, the default value of dynamic modular ratio,  $\alpha_{dyn}$  is taken from SCI P 076.

For normal weight concrete	$\alpha_{dyn} = 5.39$
For lightweight concrete	$\alpha_{dyn} = 9.32$

If other value of dynamic modular ratio is required, it can be specified as user defined modular ratio on [concrete slab](#) page of member property wizard.

### 4.1.3 Section 3. Materials

[3.1 Structural steel](#)

[3.2 Concrete](#)

[3.3 Reinforcement](#)

[3.4 Shear connectors](#)

[3.5 Profiled steel sheets](#)

[3.6 Concrete flange](#)

#### 4.1.3.1 3.1 Structural steel

Grades S275, S355 of BS EN 100 025 are available but the strength can also be specified explicitly. The thickest element is used when calculating the strength from the table below.

Grade	Thickness (mm)					
	$\leq 16$	$\leq 40$	$\leq 63$	$\leq 80$	$\leq 100$	$\leq 150$
S275	275	265	255	245	235	225
S355	355	345	335	325	315	295
S460	460	440	430	410	400	N/A

#### 4.1.3.2 3.2 Concrete

Aggregate size not considered.

No other types than normal and light weight concrete are allowed.

#### 4.1.3.3 3.3 Reinforcement

Longitudinal reinforcement is not required for the beam design. Mesh reinforcement can be defined on the Reinforcement page of Member Property wizard. This is used in shear calculations at web openings (see Step 6, appendix [SCI P 068 Implementation](#)) and slab transverse shear capacity calculation.

The modulus of elasticity of reinforcement is taken as 205 GPa and is fixed by the program.

#### 4.1.3.4 3.4 Shear connectors

Standard and user defined headed studs shear connectors can be used.

#### 4.1.3.5 3.5 Profiled steel sheets

Profiled steel sheets can be chosen from decking database. User defined profiled steel sheets can also be defined.

#### 4.1.3.6 3.6 Concrete flange

Negative moments are not considered, so concrete flange is always in compression.

### 4.1.4 Section 4. Section properties

[4.1 Modular ratio](#)

[4.2 Second Moment of area](#)

[4.3 Elastic Section Modulus](#)

[4.4 Moment Capacity](#)

[4.5 Limiting proportions of cross sections](#)

[4.6 Effective Breadth of Concrete Flange](#)

#### 4.1.4.1 4.1 Modular ratio

The modulus ratios between steel and concrete materials are defined on "[Concrete slab](#)" page of Member Property wizard. The effective modular ratio is calculated based on the unfactored applied dead and live loads. Some percentage of live load can be considered as dead load in the modular ratio calculation. The percentage of live load taken as dead load can be defined on "[Concrete slab](#)" page of Member Property wizard. The default percentage is 33%.

#### 4.1.4.2 4.2 Second Moment of area

Second moment of area are calculated for the composite beam under dead loads and live loads. Effective second moment of area is also calculated. Second moment of area for vibration is also calculated. Cracked section is used for calculating the second moment of area except for the second moment of area for vibration.

Concrete within the depth of the ribs is conservatively neglected.

#### 4.1.4.3 4.3 Elastic section modulus

Elastic section modulus are calculated based on the relevant second moment of area of the section and the neutral axis positions.

#### 4.1.4.4 4.4 Moment Capacity

Concrete within the ribs is neglected.

A general method of calculating the moment capacity of the composite section is used, which allows for beams of unequal flanges.

The thickness of the profiled steel sheet is ignored when calculating the beam properties.

The effective width on each side of the beam is limited to  $L/8$ . For beams spanning parallel to deck the effective width is further limited to  $0.8 \times$  available width.

Reinforcement is not considered.

### 4.3.3 Elastic Moment Capacity

In some cases, the concrete of a Composite section can fail before the elastic capacity of the steel section alone is reached. In such cases, the elastic moment capacity of the Composite section is taken to be the same as that of the steel beam alone.

#### 4.1.4.5 4.5 Limiting proportions of cross sections

##### Construction Stage

BS5950 part 1 is used to classify the sections and evaluate the section capacity.

##### Composite Stage

The classification of the flange in accordance with table 11 of Part 1 is modified according to clause 4.5.2. The section classification is summarized in the following table.

		Web Classification			
		Plastic	Compact	Semi-compact	Slender
Flange Classification	Plastic	Full Plastic	Full Plastic	Plastic (reduced web)	Elastic (reduced web)
	Compact	Full Plastic	Full Plastic	Plastic (reduced web)	Elastic (reduced web)
	Semi-compact	Full Elastic	Full Elastic	Full Elastic	Elastic (reduced web)
	Slender	Elastic (reduced flange)	Elastic (reduced flange)	Elastic (reduced flange)	Elastic (reduced flange and web)

##### Full Plastic

plastic stress block method is used to calculate the section moment capacity. The maximum compressive force of concrete slab is limited by the shear resistance of shear studs from the section in question to the end of the beam.

##### Plastic (reduced web)

plastic stress block method is used with effective web as give by Figure 2 in Part 3.1 of BS5950. The maximum compressive force of concrete slab is also limited by the shear resistance of shear studs from the section in question to the end of the beam.

##### Full Elastic

Linear stress distribution is assumed. The moment capacity of the composite section is calculated based on the elastic modulus of the composite section and the allowable stress of both steel and concrete. The allowable stress of steel beam is  $p_y/\gamma_m$ , where  $\gamma_m$  is the material partial safety factor (1.0 used by BS5950), and  $p_y$  is steel design strength. The allowable stress of concrete is  $0.67f_{cu}/\gamma_m$

where  $f_{cu}$  is the cube strength of concrete and  $\gamma_m$  is the material partial safety factor (1.5 used by BS8110). The maximum compressive force of concrete slab is also limited by the shear resistance of shear studs.

**Elastic (reduced flange and/or web)**

Linear stress distribution is assumed. Reduced flange (Figure 8 in Part 1 of BS5950) and/or reduced web are used to calculate the elastic modulus of the composite section. The effective web (reduced web) is calculated as follows:

According to Figure 1 in Part 3.1 of BS5950, the  $r$  ratio is calculated. Using this  $r$  value, the effective depth ( $D_w$ ) of the steel beam web is calculated according to Table 2 in Part 3.1 of BS5950 as follows (use the web depth for semi-compact web as the effective web depth for slender web)

if  $r$  is greater than 0.66 and it is a rolled section,

$$D_w = \frac{114\varepsilon}{1+2r} t_w$$

if  $r$  is greater than 0.66 and it is a welded section,

$$D_w = \left( \frac{41}{r} - 13 \right) \varepsilon t_w$$

if  $r$  is greater than or equal to zero and smaller than 0.66,

$$D_w = \frac{114\varepsilon}{1+2r} t_w$$

if  $r$  is smaller than zero,

$$D_w = \frac{114\varepsilon(1+r)}{(1+2r)^{3/2}} t_w$$

where  $t_w$  is the web thickness

According to  $f_1$  and  $f_2$  calculated according to Figure 1 in Part 3.1 of BS5950, the effective compressive depth ( $D_{wc}$  - the effective depth of the web above neutral axis) of the steel beam web can be calculated from:

if  $f_2$  is in compression (the whole web is in compression)

$$D_{wc} = D_w$$

if  $f_2$  is in tension

$$D_{wc} = \frac{|f_1|}{(|f_1| + |f_2|)} D_w$$

After calculated  $D_{wc}$ , the effective web section used in calculating the elastic modulus of the composite section is as shown below (the same as Figure 9 in Part 1 of BS5950 except  $D_{wc}$  is used here).

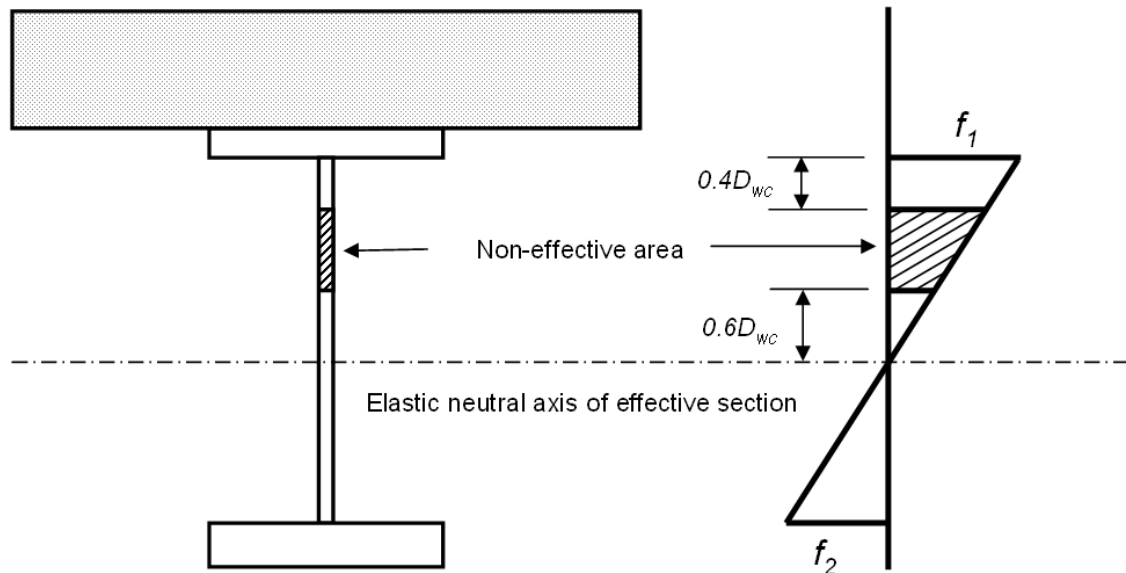

After calculating the elastic modulus of the composite section, the moment capacity of the composite section is determined in the same way as for "Full Elastic" section based on both steel beam and concrete design strengths.

#### 4.1.4.6 4.6 Effective Breadth of Concrete Flange

The user may specify the effective or available width for each side of the beam.

If available widths are specified, Compos calculates the effective width on each side within the limits mentioned in the clause:

- Transverse beams: Minimum of Span/8 and available width
- Parallel beams: Minimum of Span/8 and (0.8 × available width)
- 45 degree rule is also used to determine the effective width and the end of the beam as well as at the adjacent of changes of concrete slab section

### 4.1.5 Section 5. Composite beams: Ultimate limit state

#### [5.1 General](#)

#### [5.2 Moments in continuous beams](#)

#### [5.3 Design of members](#)

#### [5.4 Shear connection](#)

#### [5.5 Partial shear connection](#)

#### [5.6 Transverse Reinforcement](#)

**4.1.5.1 5.1 General**

The user specifies the effective span.

Cantilevers are not dealt with.

**5.1.2 Unpropped construction**

In the serviceability analysis, when calculating deflections, the effect of loading acting on beam alone (before concrete has hardened) is considered separately to the load acting on the composite section.

**5.1.3 Propped Construction**

All final stage loading is applied to the composite member.

**5.1.4 Vertical shear force**

The moment capacity is reduced in accordance with [clause 5.3.4](#) when the shear force is high.

**4.1.5.2 5.2 Moments in continuous beams**

Compos does not include continuous beams.

**4.1.5.3 5.3 Design of members**

Only simply supported beams are considered

**5.3.2 Cantilevers**

Compos does not include cantilevers.

**5.3.3 Continuous beams**

Compos does not include continuous beams.

**5.3.4 Moment capacity with high shear load**

The shear capacity is calculated independent of the moment capacity and no reduction is made to the shear capacity of steel if the beam is slender.

In the composite stage a reduced moment capacity is used when the applied shear force exceeds  $0.5 \times P_v$  where  $P_v$  is the lesser of:

- The shear capacity, calculated from Part 1 Clause 4.2.3, using (b) for plate girders and (a) for all others.
- The shear buckling resistance, calculated using Clause 4.4.5.2 of Part 1. It is conservatively assumed that no transverse stiffeners are used.

**5.3.5 Stability of compression flange**

The program assumes that the compression flange is laterally restrained in composite stages.

**4.1.5.4 5.4 Shear connection****5.4.2 Type of shear connectors**

Standard (Table 5) and user defined shear connectors can be used. If user defined shear connectors are used, the characteristic strength, as-welded length and diameter must be specified.

**5.4.3 Capacities of shear connectors in solid slabs**

The design strength of the shear connectors is taken as  $Q_d$  factor, the default value for the stud material factor is taken as 1.25.

#### 5.4.4 Provision of shear connectors.

Concrete within the ribs is neglected. The total number of shear connectors needed for 100% interaction is calculated at all interesting points along the beam. For plastic sections,  $F_p$  is taken as the lesser of  $(A \times p_y)$  and  $(0.45f_{cu} \times \text{concrete area})$

For elastic sections,  $F_p$  is taken as the total force carried in the concrete at the ultimate final moment capacity.

#### 5.4.5 Spacing of shear connectors

##### 5.4.5.1 General

The automatic design option will ensure that there is sufficient shear capacity at all points along the beam.

##### 5.4.5.2 to 5.4.5.5

The adequacy of shear connection is always checked at all the critical sections along the beam.

#### 5.4.6 Headed studs in solid slabs

Table 5 and the modifications for light weight concrete are implemented.

#### 5.4.7 Headed studs in composite slabs

In calculating  $k$ , it is assumed that studs are located centrally. Where they cannot be placed centrally (e.g. because of deck ribbing) single studs must be placed on the beneficial side (normally towards the supports). Pairs of studs can be placed alternatively on each side.

##### 5.4.7.1 General

The checks in this clause are made if standard studs from Table 5 are used.

##### 5.4.7.2/3 Ribs perpendicular/parallel to the beam

The capacity of studs is reduced by the factor  $k$  if the decking is not a solid slab.  $br$  is taken as the average trough width if the profile is trapezoidal and as the minimum width if the decking is a dove-tail.

#### 5.4.8 Dimensional details

##### 5.4.8.1 Maximum spacing

The maximum spacing rules are incorporated.  
Shear connectors may be arranged in groups of up to 3 rows and 7 lines.

##### 5.4.8.2 Edge distance

This check is carried out and a warning is given if it is necessary to stagger the studs.

##### 5.4.8.3 Haunches

Haunches are not included.

##### 5.4.8.4 Stud shear connectors

###### 5.4.8.4.1 Minimum spacing

Minimum longitudinal spacing is 5 times diameter of studs. The longitudinal spacing rule is incorporated in the automatic spacing but not the rule for spacing of adjacent studs.

###### 5.4.8.4.2 Maximum diameter

The program carries out a check on the flange thickness using the ratio 2.5:1.

##### 5.4.8.5 Other types of shear connectors

User must ensure that spacings and dimensional details are satisfactory.

#### 4.1.5.5 5.5 Partial shear connection

##### 5.5.1 Conditions

Partial shear connection is allowed for both standard and user defined shear connectors.

##### 5.5.2 Number of shear connectors

A check is made to ensure that the lower limit of partial interaction is satisfied.

#### 4.1.5.6 5.6 Transverse Reinforcement

##### 5.6.2 Shear to be resisted

The shear force to be resisted is calculated using the actual number of studs at the place where the stud spacing is the smallest. If the actual shear interaction is larger than 120%, the calculated transverse shear will be factorised by  $1/(s - 0.2)$ , where  $s$  is the shear interaction at maximum moment section in decimal format.

##### 5.6.3 Resistance of concrete flange

The resistance of the concrete is calculated using Figure 7 of Part 3.1 and taking account of the difference in shear surface for beams with different available widths on the two sides.

For parallel decking the shear surface depth is taken as the minimum slab depth (ie not including trough depth). For transverse decking, an average shear surface depth is used, which accounts for the concrete in the decking troughs.

For a solid slab, reinforcement is calculated for both a-a and b-b shear planes (see Figure 7, Part 3.1) and the maximum selected.

The required resistance and the concrete and decking resistances are given as a results.

##### 5.6.4 Contribution of profiled steel sheeting

The profiled steel decking is assumed not to contribute to the resistance if the beam span is parallel to the decking. If the profile steel decking has an angle with the steel beam, the profiled steel decking transverse shear resistance is calculated from  $\sin(a)v_p$ , where  $a$  is the angle between decking and steel beam,  $v_p$  is the decking transverse shear resistance if it is perpendicular to the steel beam.

The resistance of the profile in conjunction with transverse beams can only be utilised if the studs are staggered (welded) at butt joints.

##### 5.6.5 Longitudinal splitting

The program checks whether the slab projection beyond the edge of the flange is greater than  $6d$ .

#### 4.1.6 Section 6. Composite beams: Serviceability

[6.1 Deflections](#)

[6.2 Irreversible deformation](#)

[6.3 Cracking](#)

[6.4 Vibration](#)

#### 4.1.6.1 6.1 Deflections

No deflection checks are made for propped construction at the construction stage.

The propping is assumed only to be applied at construction stage.

##### 6.1.2 Simply supported beams

Uncracked section properties are used.

##### 6.1.3 Continuous beams

Not included.

##### 6.1.4 Partial shear connection

The increased deflection under partial shear connection is calculated by applying the percentage interaction at the critical section to all points along the beam.

The critical section is defined as the point along the beam which has the largest ratio of applied ultimate moment to section area.

#### 4.1.6.2 6.2 Irreversible deformation

Stresses are checked at all critical sections. See comments to [2.4](#).

#### 4.1.6.3 6.3 Cracking

Cracking is not included in Compos.

#### 4.1.6.4 6.4 Vibration

Vibration is calculated using energy method. Raleigh-Ritz method can be used by setting the preference, otherwise, the deflection shape will be used as the mode shape to calculate the natural frequency. See also comments to [2.4](#).

#### 4.1.7 Appendix A. Guidance on additional aspects of construction

Compos does not cover such detail.

#### 4.1.8 Appendix B. Plastic moment capacity

Not used. A general method that allows for beams with unequal flanges has been developed.

#### 4.1.9 Appendix C. Classification of webs

##### C.1 Plastic stress distribution

C.1.2 and C.1.3 are used to calculate the ratio  $r$  and the force in the concrete flange.

##### C.2 Elastic Stress distribution

Figure 1(b) is used instead of C.2.

#### 4.1.10 Appendix D. Plastic analysis, general method

Not included.

## 4.2 EN 1994-1-1:2004 Interpretation

The following sections describes the EN 1994-1-1:2004 interpretation by Compos.

[Section 1. General](#)

[Section 2. Basis of design](#)

[Section 3. Materials](#)

[Section 4. Durability](#)

[Section 5. Structural analysis](#)

[Section 6: Ultimate limit states](#)

[Section 7. Serviceability limit states](#)

[Section 8: Composite joints in frames for buildings](#)

[Section 9: Composite slabs with profiled steel sheeting for buildings](#)

[Appendix A. \(Informative\) Stiffness of joint components in buildings](#)

[Appendix B. \(Informative\) Standard tests](#)

[Appendix C. \(Informative\) Shrinkage of concrete for composite structures for buildings](#)

### 4.2.1 Section 1. General

The overall design procedure is in accordance with EN 1994-1-1:2004 and its reference standards except when supplemented by the recommendations of Non Contradictory Complementary Information (NCCI).

### 4.2.2 Section 2. Basis of design

#### 2.2 Principles of limit states design

Analysis is carried out at construction stage and at the final stage. During construction stage analysis the concrete slab part of the composite beam is not considered.

#### 2.4.2 Combination of actions

Compos uses the load combination according to the section 6.4.3.2 (3) of EN 1990:2000. The option is provided to override the partial load factors and load combination factors.

### 4.2.3 Section 3. Materials

[3.1 Concrete](#)

[3.2 Reinforcing steel](#)

[3.3 Structural steel](#)

[3.4 Connecting devices](#)

[3.5 Profiled steel sheeting](#)

#### 4.2.3.1 3.1 Concrete

Concrete properties are calculated according to clause 3.1 of EN 1992-1-1:2004 for normal weight concrete and clause 11.3 of EN 1992-1-1:2004 for light weight concrete.

Compos does not allow the concrete strength classes to be defined lower than C20/25 and LC20/22 or higher than C60/75 and LC60/66.

Modulus of Elasticity ratios for long-term and shrinkage are calculated according to [5.4.2.2](#) and the creep coefficient is calculated according to Appendix B of EN 1992-1-1:2004.

Shrinkage of concrete is in accordance with [Appendix C](#).

#### 4.2.3.2 3.2 Reinforcing steel

Longitudinal reinforcement is used to calculate the concrete shear strength at web openings (see [SCI P355 Implementation](#)) and the transverse shear capacity of the concrete slab. Reinforcement is ignored for calculating the bending strength of the composite beam.

The modulus of elasticity of reinforcement is taken as 210,000 MPa according to clause 3.2.6 of EN 1993-1-1:2005.

#### 4.2.3.3 3.3 Structural steel

Standard Grades S235, S275, S355 and S460 of BS EN 10025-2 are available as defined in Table 3.1 of EN 1993-1-1:2005 but the strength can also be specified explicitly. In Compos the grade names are modified by appending "(EN)" at the end of the grade to avoid conflict with BS5950 grades; for example "S235" is named "S235(EN)". The thickest element is used when calculating the strength from the table below.

Grade	Thickness (mm)			
	≤ 40		≤ 80	
	fy (N/mm <sup>2</sup> )	fu (N/mm <sup>2</sup> )	fy (N/mm <sup>2</sup> )	fu (N/mm <sup>2</sup> )
S235	235	360	215	360
S275	275	430	255	410
S355	355	510	335	470
S460	440	550	410	550

The modulus of elasticity of reinforcement is taken as 210 000 MPa according to clause 3.2.6 of EN 1993-1-1:2005.

#### 4.2.3.4 3.4 Connecting devices

Headed stud shear connector Grades SD1, SD2 and SD3 of BS EN ISO 13918:2008 are available; stud strengths can also be specified explicitly. The following table shows the grades of studs and their corresponding shear strengths.

Grade	Shear Strength (N/mm <sup>2</sup> )
SD1	450
SD2	500
SD3	500

#### 4.2.3.5 3.5 Profiled steel sheeting

See [BS5950 Section 3.5](#) for details on profiles steel sheeting.

#### 4.2.4 Section 4. Durability

Not included except the detailing of the shear connectors, which is in accordance with section 6.6.5.

#### 4.2.5 Section 5. Structural analysis

[5.1 Structural modeling for analysis](#)

[5.2 Structural stability](#)

[5.3 Imperfections](#)

[5.4 Calculation of action effects](#)

[5.5 Classification of cross-sections](#)

##### 4.2.5.1 5.1 Structural modeling for analysis

Not included.

##### 4.2.5.2 5.2 Structural stability

Not included.

##### 4.2.5.3 5.3 Imperfections

Not included

##### 4.2.5.4 5.4 Calculation of action effects

###### 5.4.1.1 General

Elastic analysis is used for calculating the action effects for Ultimate Limit State and Serviceability Limit State verification.

###### 5.4.1.2 Effective width for verification of cross-sections

The user may specify the effective or available width for each side of the beam.

If available widths are specified, Compos calculates the effective width on each side within the limits mentioned in the clause 5.4.1.2:

- At mid span minimum of Span/8 and available width is considered effective.
- If the section is elastic, at end span  $\beta_1$  times the effective width at the mid span, where  $\beta_1$  is as defined in 5.4.1.2 (6)
- If the section is plastic, uniform section with effective width at mid span is considered.
- 45 degree rule is also used to determine the effective width and the end of the beam as well as at the adjacent of changes of concrete slab section

$b_0$ , the distance between the centres of the outstand shear connectors is assumed as zero for calculating the effective width of cross section.  $b_1$  is measured from the centre of opening.

The shear lag effect in steel flanges is ignored. A warning message will be given to the user if the value of kappa (see Table 3.1 of EN 1993-1-5:2006) value is greater than 0.02.

###### 5.4.2.2 Creep and shrinkage

The effect of creep and shrinkage on modular ratios is considered in accordance with equation 5.6 and the creep coefficient is calculated in accordance with Annex B of EN 1992-1-1:2004. Alternatively the modular ratio can be defined explicitly, and the simplified E Ratios according to 5.4.2.2 (11) may be used.

#### **5.4.2.4 Stages and sequence of construction**

Construction stage and final stage analysis is considered in the Compos.

At the construction stage the concrete part in the composite beam is not considered. Constraints to the steel beam can be defined on "[Restraints in construction](#)" page of the property wizard.

#### **4.2.5.5 5.5 Classification of cross-sections**

Section classification is primarily done according to clause 5.5 of BS EN 1993-1-1:2005. Compression flanges are treated as Class 1 if the spacing of connectors is in accordance with clause 6.6.5.5.

Clause 5.5.5 (3) is not included in the section classification.

### **4.2.6 Section 6: Ultimate limit states**

#### [6.1 Beams](#)

#### [6.2 Resistances of cross-sections of beams](#)

#### [6.3 Resistances of cross-sections of beams for buildings with partial encasement](#)

#### [6.4 Lateral-torsional buckling of composite beams](#)

#### [6.5 Transverse forces on webs](#)

#### [6.6 Shear connection](#)

#### [6.7 Composite columns and composite compression members](#)

#### [6.8 Fatigue](#)

#### **4.2.6.1 6.1 Beams**

##### **6.1.1 Beams for building**

The composite beam is checked for bending and vertical shear, lateral torsional buckling, shear buckling for slender webs and longitudinal shear at all the critical cross-sections.

Compos will not check the partial shear connection if the section is elastic.

##### **6.1.2 Effective width for verification of cross-sections**

Compos calculates the effective width in accordance with the clause [5.4.1.2](#)

#### **4.2.6.2 6.2 Resistances of cross-sections of beams**

The design bending resistance is determined using plastic theory according to 6.2.1.2 or 6.2.1.3 where the cross-section is in Class 1 or 2. Elastic resistance is used if the section is Class 3 or Class 4.

##### **6.2.1.2 Plastic resistance moment of a composite cross-section**

For Class 1 or 2 sections the resistance moment is calculated in accordance with this clause. For steel grade S460 the resistance moment is reduced according to the clause 6.2.1.2 (2).

### **6.2.1.3 Plastic resistance moment of sections with partial shear connection in buildings**

The resistance moment of sections with partial shear connection is calculated in accordance with 6.2.1.3 (3). The limitation on the use of partial shear interaction is checked in accordance with [6.6.1.1](#).

The option is provided to select NCCI limitation on the use of partial shear interaction (see [NCCI PN 002a - GB](#) for details).

### **6.2.1.4 Non-linear resistance to bending**

Not included

### **6.2.1.5 Elastic resistance to bending**

For Class 3 or Class 4 cross-sections the moment resistance is calculated using elastic theory. Effective section properties are used if the cross-section is Class 4.

Modular ratios are calculated according to 5.4.2.2

### **6.2.2.2 Plastic resistance to vertical shear**

The design plastic shear resistance of the structural steel section is determined in accordance with clause 6.2.6 of EN 1993-1-1:2005

### **6.2.2.3 Shear buckling resistance**

The shear buckling resistance of the web is determined in accordance with section 5 and Appendix A of EN 1993-1-5:2006. The shear resistance contribution of the flanges is ignored.

### **6.2.2.4 Bending and vertical shear**

The influence of vertical shear on the bending resistance is ignored if the vertical shear forces is less than the half of the shear resistance.

For Class 1 or 2 cross-sections, if the vertical shear force exceeds the half of the shear resistance, the reduced design steel strength is used to calculate the bending strength of the member as defined in 6.2.2.4 (2)

For Class 3 and 4 cross-sections the design strength is verified using clause 7.1 of EN 1993-1-5:2007.

## **4.2.6.3 6.3 Resistances of cross-sections of beams for buildings with partial encasement**

Not Included.

## **4.2.6.4 6.4 Lateral-torsional buckling of composite beams**

Lateral torsional buckling of the compression flange in the 'no stud' zone is checked according to EN 1993-1-1:2005.

Elastic critical moment for lateral-torsional buckling is calculated in accordance with Annex I of EN 1999-1-1:2007. When the loads on the member are not found in the appropriate table of Annex I of EN 1999-1-1:2007, the worst values of C1, C2 and C3 are taken from the appropriate table assuming the ends are pinned.

#### 4.2.6.5 6.5 Transverse forces on webs

Not included.

#### 4.2.6.6 6.6 Shear connection

##### 6.6.1.2 Limitation on the use of partial shear connection in beams for buildings

A check is made in accordance with clauses 6.6.1.2 (1) and 6.6.1.2(2) to ensure that the lower limit of partial interaction is satisfied.

##### 6.6.2 Longitudinal shear force in beams for buildings

Checks on longitudinal shear force is not included. Shear studs and longitudinal reinforcement are checked based on the capacity of concrete slab.

##### 6.6.3 Headed stud connectors in solid slabs

The design shear resistance of a headed stud is the minimum resistance calculated using equations 6.18 and 6.19. A check is made for the position of reinforcement as defined in Figure 6.14 for the solid slab. The ultimate tensile strength of studs is limited to a maximum value of 500 N/mm<sup>2</sup>.

##### 6.6.4.1 Sheeting with ribs parallel to the supporting beams

The design shear resistance of studs is taken as the resistance of the stud in solid slab multiplied by the reduction factor as defined in 6.6.4.1 (2).

If the sheeting is discontinuous and welded to the flange of the beam Compos assumes that the sheeting is anchored to the beam; if not welded a check is made for the position of reinforcement according to 6.6.5.4.

##### 6.6.4.2 Sheeting with ribs transverse to the supporting beams

The design shear resistance of studs is taken as the resistance of the stud in the solid slab multiplied by the reduction factor as defined in equation 6.23, limited to the maximum value as defined in Table 6.2. While calculating the resistance of studs in solid slabs the stud ultimate tensile strength is limited to 450 N/mm<sup>2</sup>. Checks are made on the diameter and rib height according to clause 6.6.4.2 (3) and Table 6.2.

A check is made on the position of reinforcement according NCCI PN 001a-GB and if necessary the stud strength is modified as per the modification factor in Table 2.1 (see [NCCI PN 001a-GB](#) for more details)

##### 6.6.5.1 Resistance to separation

Compos checks the position of reinforcement from the underside of the stud head.

- Solid Slab: Reinforcement should be 30 mm below.
- Decking parallel to the beam: If the decking is not continuous and not anchored to the beam, reinforcement should be 45 mm below
- Decking perpendicular to the beam: Stud strength is reduced according to the [NCCI PN 001a-GB](#) depending on the position of reinforcement.

##### 6.6.5.5 Spacing of connectors

If the spacing of the stud satisfies the criteria given in 6.6.5.5 (2) then the compression steel flange is assumed to be class 1 even if the actual classification is class 3 or 4. Checks are made for maximum centre to centre spacing of shear connectors.

##### 6.6.5.6 Dimensions of the steel flange

A warning is given if the distance between the edge of a connector and the edge of the flange is less than 20 mm and if the thickness of the flange is less than the diameter of the stud divided by 2.5,

according to 6.6.5.7 (5).

#### **6.6.5.7 Headed stud connectors**

The stud diameter, height and spacing of the headed stud connector are checked according to the rules specified in this clause.

#### **6.6.5.8 Headed studs used with profiled steel sheeting in buildings**

The stud height and decking properties are checked according to the rules specified.

#### **6.6.6.1 General**

Transverse reinforcement in the slab is designed to the full shear strength of studs, as opposed to the actual longitudinal shear force.

#### **4.2.6.7 6.7 Composite columns and composite compression members**

Not included.

#### **4.2.6.8 6.8 Fatigue**

Not included.

### **4.2.7 Section 7. Serviceability limit states**

[7.2 Stresses](#)

[7.3 Deformations in buildings](#)

[7.4 Cracking of concrete](#)

#### **4.2.7.1 7.2 Stresses**

Stresses are calculated at serviceability limit state for construction stage and final stage analysis. Uncracked section properties are used. The tensile strength of concrete is ignored.

Shear lag effects are taken into account (see [5.4.1.2](#) for more details).

Creep and shrinkage are taken into account (see [5.4.2.2](#) for more details).

#### **4.2.7.2 7.3 Deformations in buildings**

No deflection checks are made for propped construction at the construction stage and the propping is assumed only to be applied at construction stage.

The effect of incomplete interaction is ignored if the limitations on partial interaction are in accordance with 6.6. However, if the NCCI partial interaction (see [NCCI PN - 002a GB](#)) is chosen, the increased deflection under partial shear connection is calculated by applying the percentage interaction at the critical section to all points along the beam.

The effect of shrinkage of concrete is considered in the calculation of deflection. However if the user selects the 'Ignore if the ratio of length to depth is less than 20 for normal weight concrete' [Design Option](#) then Compos ignores the effect of shrinkage .

For vibration criteria see [BS 5950 6.4 Vibration](#) for more details. The following default values of dynamic modular ratios are used for vibration analysis.

For normal weight concrete	$\alpha_{dyn} = 5.526$
For lightweight concrete	$\alpha_{dyn} = 9.545$

#### 4.2.7.3 7.4 Cracking of concrete

Not included.

#### 4.2.8 Section 8: Composite joints in frames for buildings

Not included.

#### 4.2.9 Section 9: Composite slabs with profiled steel sheeting for buildings

Not included.

#### 4.2.10 Appendix A. (Informative) Stiffness of joint components in buildings.

Not included.

#### 4.2.11 Appendix B. (Informative) Standard tests

Not included.

#### 4.2.12 Appendix C. (Informative) Shrinkage of concrete for composite structures for buildings

The value of shrinkage strain is assumed as 0.000325 for normal weight concrete and 0.0005 for light weight concrete. The option is provided to override the default value of shrinkage strain.

### 4.3 SCI P 068 Implementation

Checks on input data are performed to ensure that the guidelines on the positioning and size of web openings (Section 9 of the CIRIA/SCI guide) have been followed.

If stiffeners are used, they are assumed to be compact.

The beam is first analysed assuming no holes and results are then modified to take account of any holes. The program does not necessarily follow the steps in the same sequence as they are presented, e.g. it is necessary to carry out Step 8 (section properties) before Steps 3 and 4 for non-symmetrical sections.

Circular holes are analysed as an equivalent rectangle (Section 7 of SCI P 068) of height  $0.9d$  and width  $0.45d$ .

#### Step 1

*Calculate the applied forces at the openings*

The ultimate design moment and shear force is calculated at each side of the hole.

#### Step 2

*Calculate the axial capacity of concrete and the steel*

The effective width in BS5950:Part 3:Section 3.1:1990 is used rather than the value used in the

Guide.

The area of any stiffener is included in determining  $F_{yb}$ .

### Step 3

*Determine the tensile force in the lower web-flange (assuming adequate shear connection)*

$T_1$  and  $x_c$  are calculated directly by solving a set of equations, no iteration is necessary.

### Step 4

*Check the degree of shear-connection at the opening*

As  $x_{et}$  and  $x_{eb}$  are calculated beforehand, all values can be calculated directly.

The suggested additional limit on  $T_0$  is included as a warning. To ensure that the  $x_c$  does not exceed the amount of concrete actually available (e.g. if more studs have been provided than required for 100% interaction), the limiting value used by Compos is the lesser of  $N_s \times P_1$  and  $F_c$ .

### Step 5

*Calculate the shear strength of the web*

As SCI guide.

### Step 6

*Calculate the shear resistance of concrete slab*

The formula given in BS8110 : Part 1 : 1997 is incorporated rather than Table 3.9 itself. A new material factor for concrete in shear has been added to the input of global data in Compos with a default of 1.25.

If the available/effective width on either side of the beam is less than 1.5 times the slab depth (edge beams), the shear resistance of the concrete is ignored.

### Step 7

*Determine the influence of shear on bending or axial capacity*

In the formula  $V_t = V - V_c$ , the sign of  $V$  is applied to  $V_c$  so that  $0 \leq |V_t| \leq |V - V_c|$

### Step 8

*Calculate the properties of the web-flange sections*

A general method is used to calculate all section properties which includes the effect of any stiffeners.

### Step 9

*Check local instability of the unstiffened web in compression*

Limiting values for  $s_t$  and  $s_b$  are calculated and compared with actual values. If they are exceeded, the elastic moment capacities are used for  $M_{pb}$  and  $M_{pt}$ .

If a stiffener is present, the Tee is classed as compact.

### Step 10

*Design of semi-compact or slender webs*

If a tee is classed as semi-compact or slender, elastic moment capacities are used.

If the limiting value of semi-compact sections is exceeded, a warning is produced, stating that stiffeners are required.

### Step 11

*Calculate the moment transferred by the composite action of the upper web-flange and slab at the high moment side of the opening*

An effective length of the hole is calculated by rounding up the length of the hole to a whole multiple of stud group spacings.

The force transferred by the shear connectors across the opening is calculated using the effective length of opening.

The limiting concrete force used is the lesser of  $(N_1 \times P_1)$  and  $F_c$ .

### **Step 12**

*Consider the influence of axial force on the bending capacities of the web-flange sections*

Step 12 is included in steps 14, 15 and 16.

### **Step 13**

*Calculate applied Vierendeel moment across the opening*

The effective length of hole is used in calculating the applied Vierendeel moment.

### **Step 14**

*Determine the total Vierendeel moment capacity*

As SCI guide.

### **Step 15**

*Solution for non-composite beams*

The shear force resisted by the upper and lower web sections is taken as proportional to their depth squared.

In determining  $F_{yb}$  and  $F_{yt}$  the area of any stiffener is included.  $t_e$  and  $t_e'$  are used in determining  $F_{yb}$  and  $F_{yt}$ .

The actual length of the hole is used rather than the effective. This is different from the SCI publication which uses the effective length.

### **Step 16**

*Solution for notched beams*

The effective length of hole is used in calculating the applied Vierendeel moment.

### **Steps 17**

*Shear force in lower web-flange*

If  $V_b$  is smaller than 0.5 times the shear capacity of lower web-flange,  $V_b$  is used.

### **Steps 18**

*Shear force in lower web-flange and effective web thickness*

If  $V_b$  is greater than 0.5 times the shear capacity of lower web-flange, iteration is needed to find accurate  $V_b$ . Based on  $V_b$ , the effective web thickness can be calculated.

### **Steps 19**

*Reassess the shear force in upper web-flange.*

### **Steps 20**

*Reassess the effect of shear on moment capacity.*

### **Steps 21**

Calculate the Vierendeel moment capacity.

### **Step 22**

*Serviceability performance*

A rigorous method is used to check serviceability performance (stresses and deflections).

### **Step 23**

*Additional deflections*

The additional deflections caused by the holes in the webs are calculated from a method based upon

that proposed by Tse and Dayawansa (see references).

### Step 24

#### *Stiffener requirements*

If stiffeners are used, a note is produced stating that they must be compact, and that minimum weld lengths must be checked.

## 4.4 SCI P 355 Implementation

Composite beams with large web openings are checked for various modes of failures according to section 2.3 of SCI P355. The beam is checked for local effects around openings as well as the web-post between the openings.

Circular openings are treated as equivalent rectangular openings in accordance with the clause 3.1.4. When classifying the web of Tees the effective length of the circular opening is defined according to the clause 3.4.2.

### Check for web opening

The following steps are followed for the local checks at an opening.

#### **Step 1:** *Calculate the applied forces at the openings*

The ultimate design moment at the centre of the opening. The shear force is taken as the greater of the shear force at the left and right ends of the opening.

#### **Step 2:** *Tee section classification and stiffener properties*

Tee section Class is the worse of the flange Class and web Class.

The flange of Tee sections is classified according to Table 5.2 of EN 1993-1-1:2005. If the flange is Class 3 or 4 and the spacing of the shear connector satisfies clause 6.6.5.5 of EN 1994-1-1:2004, then the flange will be treated as Class 1. If the flange is Class 4 then the portion beyond the Class 3 limits is ignored and the Tee section flange is considered as Class 3.

The web of the Tee sections is classified according to section 3.4.2 and Table 3.2 of SCI P355. If the flange is Class 1 or 2 and the web is Class 3, then the web is limited to the Class 2 limit and the web is treated as Class 2. If the web is Class 4 the portion beyond the Class 3 limits is ignored and the web is considered as Class 3.

If stiffeners are used in beams with the section is designed as Class 1 or 2, then the portion of the outstand of the stiffener in excess of the Class 2 limit is considered as ineffective. Similarly for Class 3 or 4 sections, the part of the outstand of the stiffener in excess of the Class 3 limit is considered as ineffective. The stiffener width is also limited such that the area of stiffeners is not greater than half of the cross section area of the opening.

If the Tee section is Class 1 or Class 2 then steps 3 to 16 are followed; otherwise steps 17 to 23 are followed. For notched openings steps 24 to 30 are followed for plastic verification and steps 31 to 34 are followed for elastic verification.

#### **If Tee section is Class 1 or Class 2:**

#### **Step 3:** *Shear resistance of the concrete slab*

Shear resistance of the concrete slab  $V_{c,Rd}$  is calculated using equation 12 of SCI P355.

During the construction stage analysis, the shear resistance of concrete slab is zero and steps 13 to 16.

#### **Step 4:** *Shear force and shear resistance of the tees*

Conservatively the shear force and shear resistance of the bottom tee is assumed as zero. The shear force on the top tee is calculated as  $V_{t,Ed} = V_{Ed} - V_{c,Rd}$ . The shear resistance of the top tee is calculated according to 3.3.1 of SCI P355.

**Step 5: Calculation of effective web thickness**

Effective web thickness is calculated using the equation 18 of SCI P355. This effective web thickness is used for both top and bottom Tees in the first iteration from step 6.

**Step 6: Calculation of axial force and axial strength of concrete and tees.**

Axial strength of concrete  $N_{c,Rd}$  is calculated using the equation 6 of SCI P355.  $N_{tT,Rd}$  and  $N_{bT,Rd}$  are calculated according to equation 5 of SCI P355 using the effective width of tee. Axial forces are distributed depending on N.A position.

**case 1:**  $N_{c,Rd} > N_{bT,Rd}$

$N_{bTEd}$  is calculated using equation 8 of SCI P355.  $N_{cEd}$  is the maximum of  $N_{bTEd}$  and  $n_{sc} P_{Rd}$  and  $N_{tTEd} = N_{cEd} - N_{bTEd}$ .

**case 2:**  $N_{c,Rd} < N_{bT,Rd}$

$N_{bTEd}$  is calculated using equation 10 of SCI P355.  $N_{cEd}$  is the maximum of  $N_{c,Rd}$  and  $n_{sc} P_{Rd}$  and  $N_{tTEd} = N_{cEd} - N_{bTEd}$ .

**Step 7: Moment of resistance of top and bottom Tee**

Moment of resistance of top and bottom Tees is calculated using plastic theory. Moment of resistance depends on the effective properties of the web and stiffeners.

**Step 8: Moment of resistance in present of Axial force.**

Moment of resistance of Tees calculated in step 7 is modified for taking the axial force into account as defined in equation 20. In the first iteration steps 9 and 10 are skipped.

**Step 9: Vierendeel resistance due to local composite action.**

Vierendeel resistance due to local composite action,  $M_{v,c,Rd}$  is calculated in accordance with section 3.4.6 of SCI P355.

**Step 10: Check for Vierendeel bending resistance**

Section is checked for Vierendeel bending resistance according to section 3.4.1 of SCI P 355. If the check satisfies equation 14 of SCI P355 then the iterations stop at step 11. It is assumed that the shear force distribution is achieved in 100 iterations. If equation 14 is not satisfied then Compos reports that the opening has failed in Vierendeel bending resistance.

**Step 11: Shear force distribution**

Shear force in the bottom tee,  $V_{b,Ed}$  is calculated according to equation 21 of SCI P355 and shear force in the top tee is calculated as  $V_{t,Ed} = V_{Ed} - V_{b,Ed}$ .

**Step 12: Calculation of effective web thickness of tees**

Effective web thickness of top and bottom Tee webs are calculated based on shear stress distribution and shear resistance.

**Steps 6 to 12 are repeated until step 10 is satisfied.**

**Step 13: Axial and shear force distribution in construction stage**

Axial forces in the section are distributed as  $N_{bTEd} = N_{tTEd} = M_{Ed} / (D - z_t - z_b)$ .

Shear stress is distributed in accordance with the section 7 of SCI P068. The shear is distributed in upper and lower Tees in proportion to their depth squared.

**Step 14:** *Calculation of effective web thickness of tees*

Effective web thickness of top and bottom Tees is calculated based on shear stress distribution and shear resistance.

**Step 15:** *Moment of resistance of top and bottom tee*

Moment of resistance of top and bottom Tees is calculated using plastic theory. The moment of resistance is modified for the effect of axial force.

**Step 16:** *Check for Vierendeel bending resistance*

Section is checked for Vierendeel bending resistance according to section 3.4.1 of SCI P 355.

**If Tee section is class 3 or class 4:**

**Step 17:** *Calculation of axial force and axial strength of concrete and tees*

Elastic neutral axis and moment of inertia are computed using the elastic properties of the section. Maximum allowable axial strength of concrete, and top and bottom steel are computed so that the maximum stresses in concrete and steel are within allowable limits. Axial forces are calculated based on the elastic stress distribution.

For construction stage analysis axial forces are calculated as  $N_{bTEd} = N_{tTEd} = M_{Ed}/(D-zt-zb)$  and steps 21 to 23 will be followed.

**Step 18:** *Moment of resistance of top and bottom Tees*

Moment of resistance of top and bottom Tees are calculated using elastic theory and the moment of resistance is modified for the effect of axial force according to equation 23 of SCI P355

**Step 19:** *Vierendeel resistance due to local composite action.*

Vierendeel resistance due to local composite action,  $M_{vCRd}$  is calculated as specified in step 9.

**Step 20:** *Check for Vierendeel bending resistance*

Section is checked for Vierendeel bending resistance according to section 3.4.1 of SCI P 355.

**Step 21:** *Shear force distribution in construction stage*

Shear stress is distributed as specified in step 13.

**Step 22:** *Moment of resistance of top and bottom tee*

Moment of resistance of top and bottom tee are calculated using elastic theory and the moment of resistance is modified for the effect of axial force according to equation 23 of SCI P 355.

**Step 23:** *Check for Vierendeel bending resistance*

Section is checked for Vierendeel bending resistance according to section 3.4.1 of SCI P 355.

**Plastic verification for notched openings:**

**Step 24:** *Shear resistance of the concrete slab*

Shear resistance of the concrete slab  $V_{c,Rd}$  is calculated using equation 12 of SCI P355.

During the construction stage analysis the shear resistance of the concrete slab is taken as zero.

**Step 25:** *Shear force and shear resistance of the top Tee*

The shear force on the top tee is calculated as  $V_{t,Ed} = V_{Ed} - V_{c,Rd}$ . The shear resistance of the top tee is calculated according to 3.3.1 of SCI P355.

**Step 26: Calculation of effective web thickness**

Effective web thickness of the Tee is calculated using the equation 18 of SCI P355.

**Step 27: Calculation of axial force and axial strength of concrete and top Tee.**

Axial strength of concrete  $N_{c,Rd}$  is calculated using the equation 6 of SCI P355.

$N_{t,Rd}$  is calculated according to equation 5 of SCI P355 using the effective width of the tee.

During the final stage analysis forces in the top tee and concrete is calculated as  $N_{t,Ed} = N_{c,Ed} = n_{sc} P_{Rd}$

For construction stage analysis axial forces are calculated as  $N_{t,Ed} = N_{c,Ed} = 0$ ;

**Step 28: Moment of resistance of Tee**

Moment of resistance of top Tee is calculated using plastic theory using effective properties of web and stiffeners.

Moment of resistance is modified to take axial force into account.

**Step 29: Vierendeel resistance due to local composite action.**

Vierendeel resistance due to local composite action,  $M_{v,c,Rd}$  is calculated in accordance with section 3.4.6 of SCI P355.

**Step 30: Check for Vierendeel bending resistance**

Section is checked for Vierendeel bending resistance according to section 7.3 of SCI P 355.

**Elastic verification for notched openings:****Step 31: Calculation of axial force and axial strength of concrete and top Tee**

Axial force and axial strength are calculated as defined step 27.

**Step 32: Moment of resistance of Tee**

Moment of resistance of Tee is calculated using elastic theory and the moment of resistance is modified for the effect of axial force according to equation 23 of SCI P355.

**Step 33: Vierendeel resistance due to local composite action.**

Vierendeel resistance due to local composite action,  $M_{v,c,Rd}$  is calculated as specified in step 9.

**Step 34: Check for Vierendeel bending resistance**

Section is checked for Vierendeel bending resistance according to section 7.2 of SCI P355.

**Check for web-post between opening**

Web-post between the openings is checked for longitudinal shear, compression due to transfer of vertical shear and bending developed due to Vierendeel action.

**Check for longitudinal shear force in the web-post**

Design longitudinal shear force in the web-post is calculated using equation 31 of SCI P355. The longitudinal shear resistance is calculated using equation 36 of SCI P355.

**Check for compression forced in web-post**

Design compression force in web-post is calculated using section 3.5.2 and compressive buckling resistance is calculated in accordance with the section 3.5.5 of SCI P355

**Check for Design moment in web-post**

Design moment in the web-post is calculated using equation 35 of SCI P355 and design bending resistance is calculated according to the section equation 44 of SCI P355.. Rectangular openings are checked according to equation 45 of SCI P355.

### Effect of web open on the deflection

The additional deflections due to holes in the web are calculated using a similar approach to that proposed in the [SCI P 068 Implementation](#).

## 4.5 NCCI PN-001a GB Implementation

### NCCI: Resistance of headed stud shear connectors in transverse sheeting

#### 1. General

The design shear resistance of headed stud connectors used with sheeting profiles spanning perpendicular to the beam is given by clause [6.6.4.2](#) of BS EN 1994-1-1. Clause [6.6.5.1](#) states that "*the surface of a connector that resists separation forces (for example, the underside of the head of a stud) should extend not less than 300 clear above the bottom reinforcement*".

This reference is providing guidance to compute the design shear resistance of the stud connectors when the reinforcement position is not satisfying clause 6.6.5.1.

#### 2. Resistance Values

The design shear resistance of headed stud connectors when the ribs run perpendicular to the beam is calculated in accordance with clause [6.6.4.2](#) of BS EN 1994-1-1 except that equation 6.19 of BS EN 1994-1-1 is multiplied by the factor  $k_{mod}$  given in the table below.

Number of studs per trough	Position of mesh	$k_{mod}$ (mm)
1	Above the heads of the studs	1.0
1	At least 10 mm below the heads of the studs	1.0
2	Above the heads of the studs	0.7
2	At least 10 mm below the heads of the studs	0.9

## 4.6 NCCI PN-002a GB Implementation

### NCCI: Modified limitation on partial shear connection in beams for buildings

#### 1. General

Limitation on the partial shear interaction for headed stud shear connectors within certain dimensional limits is suggested by clause 6.6.1.2 of BS EN 1994-1-1. This reference states that this limitation suggested by 6.6.1.2 of BS EN 1994-1-1 is based on a characteristic slip of 6 mm and this has been calibrated for propped construction which is conservative for unpropped construction.

This reference also states that "*For 19 mm diameter headed stud shear connectors through deck welded into transversely oriented trapezoidal decking profiles characteristic slip capacities in excess of 10 mm are achievable*".

The rules provided herein for limitation on the minimum degree of shear connection are lower than the limit suggested by BS EN 1994-1-1.

If the rules specified by this reference applied to the composite beam the effect of the incomplete interaction will be considered as defined in section 3.

The limit on partial shear interaction for beams with trapezoidal decking running perpendicular to the beam is specified in 2.2.1 for propped construction and 2.2.2 for unpropped construction.

If the above condition is not satisfied and the beam unpropped during the construction stage rules specified in 2.1 will be used.

If the rules specified by this reference is not satisfied the composite beam will be design according to the rules specified by 6.6.1.2 of BS EN 1994-1-1.

### **2.1 General limits for unpropped construction**

The rules specified in this section will be used if the section is unpropped and the limits specified in 2.2 are not applicable.

#### **2.2.1 Limits for propped construction**

The limit on partial interaction will be used if this section is applicable.

### **3. Effect of partial interaction on deflection**

If 'Use NCCI limits on minimum percentage of interaction if applicable' is set in the [Shear Studs](#) member properties then the effect of the partial interaction on deflection will be considered according to this section.

## **4.7 References**

1. British Standards Institution. BS5950 : Part 1 : 1990. Structural use of steelwork in building. Part 1. Code of practice for design in simple and continuous construction. BSI, 1990
2. British Standards Institution. BS5950 : Part 3: Section 3.1 : 1990. Structural use of steelwork in building. Part 3.1 Code of practice for design of simply and continuous composite beams. BSI, 1990.
3. Eurocode No.3. Design of Steel Structures Part 1.1. ENV 1993-1-1, 2/1992.
4. Eurocode No.4. Design of Composite Steel and Concrete Structures. Part 1. Revised draft 3/1992.
5. Neville A.M (1981). Properties of Concrete, Third Edition.
6. Steel Construction Institute. Publication 055. Design of composite slabs and beams with steel decking. R.M.Lawson. SCI, 1989.
7. Steel Construction Institute. Publication 059. Design of fabricated composite beams in buildings. G.W.Owens. SCI, 1989.
8. Steel Construction Institute. Publication 068. Design for openings in the webs of composite beams. R.M.Lawson, SCI, 1987. Also published as CIRIA Special Publication 51.
9. Steel Construction Institute. Publication 076. Design guide on the vibration of floors. T.A.Wyatt, SCI, 1989.
10. Steel Construction Institute. Publication 078. Commentary on BS 5950 Part 3: Section 3.1 'Composite Beams'. R.M. Lawson. SCI, 1990.
11. Tse, D & Dayawansa, P H, "Elastic deflection of steel and composite beams with web penetrations". 'The Structural Engineer' Vol 70/No 21, 3 November 1992.
12. Ross, D, Ungar, E E & Kerwin, E M, "Damping of plate flexural vibration by means of viscoelastic laminae".

13. Willford, M & Young, P, "Towards a consistent approach to the prediction of footfall-induced structural vibration", Ove Arup & Partners.
14. Katherine Benton & John Blanchard "Von Mises and the deviant flange" Structures notes 1991NST\_4, Arup, 17 May 2002.

# Index

## A

- analysis
  - analysis 30
  - analysis and design 30

## C

- COM interface
  - C++ example 39
  - COM automation 36
  - COM functions 36
  - VBA example 38

## D

- data
  - data manager 9
  - input data 11
- data file
  - data file 35
- deflection
  - web opening effect on deflection 49
- design
  - analysis and design 30
  - design 31

## E

- export
  - import/export 35

## F

- features
  - analysis and design 2
  - program features 3
- file
  - data file 35
  - I/O 35
  - import/export 35
  - key word 35

- text file 34

## G

- graphic
  - 2D view 30
  - 3D view 29
  - graphic view 29
- group
  - create member and group 12
  - new group 12

## I

- import
  - import member 10
  - import/export 35

## J

- job title
  - job titles: 7

## L

- load 53

## M

- member
  - concrete slab 22
  - create member and group 12
  - decking 24
  - design criteria 17
  - design options 16
  - editing member properties 15
  - floor responses 28
  - loads 27
  - member template 14
  - member titles 16
  - new member 13
  - program default member 15
  - reinforcement 23
  - restraints 21
  - safety factors 18
  - shear studs 25
  - steel beam 20
  - web openings 26

modular ratio  
 effective modular ratio 56

## N

note  
 concrete slab depth and width 50  
 construction loads 42  
 critical sections 42  
 longitudinal shear force 42  
 minimum percentage of shear interaction 43  
 optimal beam design 45  
 shear stud design 46  
 tapered beam 47  
 technical notes 42  
 web opening analysis 49  
 web opening effect on deflection 49  
 welding design 50

## O

optimisation  
 optimal beam design 45  
 output  
 graphic output 33  
 output 11  
 results and output 32  
 text output 32

## P

preferences  
 3D graphic operation 11  
 advanced features 12  
 input data 11  
 miscellaneous 11  
 output 11  
 preferences 10  
 unit 11  
 programming interface  
 programming interface 35  
 properties  
 concrete slab 22  
 decking 24  
 design criteria 17  
 design options 16  
 editing member properties 15  
 floor responses 28

loads 27  
 member titles 16  
 reinforcement 23  
 restraints 21  
 safety factors 18  
 shear studs 25  
 steel beam 20  
 web openings 26

## R

results  
 graphic output 33  
 results and output 32  
 text output 32

## S

second moment of area 56

## T

technical  
 concrete slab depth and width 50  
 construction loads 42  
 critical sections 42  
 longitudinal shear force 42  
 minimum percentage of shear interaction 43  
 optimal beam design 45  
 shear stud design 46  
 tapered beam 47  
 technical notes 42  
 web opening analysis 49  
 web opening effect on deflection 49  
 welding design 50  
 text file  
 I/O 35  
 key word 35

tools  
 remove empty group 34  
 sort members in ascending order 34  
 sort members in descending order 34  
 tools 33

## U

unit  
 unit 11

## V

### VBA interface

C++ example 39

COM automation 36

COM functions 36

VBA example 38

### visual basic interface

C++ example 39

COM automation 36

COM functions 36

VBA example 38

## Y

young's modulus 54

Endnotes 2... (after index)

